



HK32ASPIN010xB Datasheet

Version: 1.0

Release Date: 2023-06-09

Shenzhen Hangshun Chip Technology R&D Co., Ltd.

<http://www.hsxp-hk.com>

Preface

Purpose

This document introduces the block diagram, memory mapping, peripheral interfaces, electrical characteristics, and pinouts of HK32ASPIN010xB series microcontrollers (MCUs). This document helps you quickly understand the characteristics and functions of HK32ASPIN010xB.

Audience

This document is intended for:

- HK32ASPIN010xB developers
- HK32ASPIN010xB testers
- HK32ASPIN010xB users

Release Notes

This document is applicable to HK32ASPIN010xB series MCUs.

Revision History

Version	Date	Description
1.0	2023/06/09	The initial release.

Contents

1 Introduction	1
2 Product overview	2
2.1 Features	3
2.2 Device overview	5
3 Function description	7
3.1 Block diagram	7
3.2 Memory mapping.....	8
3.3 Flash	8
3.4 SRAM.....	8
3.5 Resets	8
3.5.1 System reset.....	8
3.5.2 Power reset	9
3.6 Clocks and clock tree.....	10
3.7 Power supply scheme	10
3.8 Boot modes.....	11
3.9 PVD.....	11
3.10 Low-power modes.....	11
3.11 NVIC	12
3.12 EXTI.....	13
3.13 IWDG.....	14
3.14 WWDG	14
3.15 SysTick timer.....	14
3.16 Timers	15
3.16.1 Basic timer	15
3.16.2 General-purpose timer.....	15
3.16.3 Advanced timer	15
3.16.4 Low-power timer	16
3.17 IRTIM.....	16
3.18 I2C	16
3.19 USART.....	17
3.20 LPUART.....	17
3.21 SPI/I2S	18
3.22 GPIO	18
3.23 DMA	18
3.24 ADC.....	18
3.25 CAN	19

3.26 RTC clock.....	19
3.27 CRC calculation unit	20
3.28 EMACC	20
3.29 DVSQ calculation unit	20
3.30 CLU	20
3.31 Voltage comparator	21
3.32 Internal reference voltage	21
3.33 Temperature sensor	21
3.34 96-bit UID.....	21
3.35 Debug port.....	21
4 Electrical characteristics.....	22
4.1 Absolute maximum values.....	22
4.1.1 Voltage characteristics	22
4.1.2 Current characteristics	22
4.1.3 Temperature characteristics	22
4.2 Operating conditions.....	22
4.2.1 Recommended operating conditions	22
4.2.2 PVD characteristics	23
4.2.3 POR/PDR characteristics	23
4.2.4 Internal reference voltage.....	23
4.2.5 Operating current characteristics	23
4.2.6 HSE clock characteristics	25
4.2.7 LSE clock characteristics	25
4.2.8 HSI clock characteristics	26
4.2.9 LSI clock characteristics	27
4.2.10 PLL characteristics	27
4.2.11 Flash memory characteristics	27
4.2.12 I/O pin input characteristics.....	27
4.2.13 I/O pin output characteristics	27
4.2.14 NRST pin characteristics	28
4.2.15 TIM timer characteristics	28
4.2.16 EMACC characteristics.....	28
4.2.17 ADC characteristics	28
4.2.18 Temperature sensor characteristics	31
5 Typical circuitry	32
6 Pinouts and pin descriptions.....	33
6.1 TSSOP20.....	33
6.2 QFN28	34

6.3 QFN32	34
6.4 LQFP32	35
6.5 LQFP48	35
6.6 LQFP64	36
6.7 Pin descriptions	36
6.8 Alternate function table.....	42
7 Package characteristics.....	45
7.1 TSSOP20	45
7.2 QNF28	46
7.3 QFN32	47
7.4 LQFP32	48
7.5 LQFP48	49
7.6 LQFP64	50
8 Ordering information	51
9 Acronyms.....	52
10 Legal and contact information.....	53

1 Introduction

This document is the datasheet for HK32ASPIN010xB series MCUs. HK32ASPIN010xB is a family of dedicated MCUs developed for motors by Shenzhen Hangshun Chip Technology R&D Co., Ltd. (hereinafter referred to as Hangshun). This MCU family includes:

- HK32ASPIN010FBP6
- HK32ASPIN010GBU6
- HK32ASPIN010KBU6
- HK32ASPIN010KBT6
- HK32ASPIN010CBT6
- HK32ASPIN010RBT6

For more details of HK32ASPIN010xB, see *HK32ASPIN010xB User Manual*.

2 Product overview

HK32ASPIN010xB adopts the ARM® Cortex®-M0 core operating at a maximum frequency of 96 MHz and has 124 Kbytes of flash and 10 Kbytes of SRAM. You can configure the Flash controller register to remap interrupt vectors in the main Flash.

HK32ASPIN010xB supports conventional Flash readout protection (RDP) Level 0, Level 1, and Level 2 and provides the patented Flash code encryption function of Hangshun.

To meet the security requirements of various applications, HK32ASPIN010xB supports hardware cyclic redundancy check (CRC). The CRC hardware implementation unit can be used to verify data accuracy and data integrity during data transmission and storage.

HK32ASPIN010xB incorporates a wide selection of communication interfaces:

- 2 × USARTs and 1 × LPUART (up to 12 Mbit/s)

The USARTs support synchronous and asynchronous full-duplex or half-duplex communication, multiprocessor communication, LIN protocol, Smart Card protocol, and IrDA SIR ENDEC. The RX and TX pins can be exchanged by using the software. The USARTs and LPUART can wake up the MCU from Stop mode when receiving data.

- Up to 2 × high-speed SPIs/I2Ss (up to 18 Mbit/s)

The SPIs/I2Ss support the 4-bit to 16-bit full-duplex or half-duplex communication, master/slave mode, TI mode, NSS pulse mode, automatic CRC, and I2S protocol.

- Up to 2 × high-speed I2Cs (up to 1 Mbit/s)

The I2Cs support the 1 Mbit/s, 400 Kbit/s, and 100 Kbit/s transmission rates, master/slave mode, multimaster mode, 7-bit/10-bit addressing, and SMBus protocol. The I2Cs can wake up the MCU from Stop mode when receiving data.

HK32ASPIN010xB embeds a 16-bit advanced PWM timer (four PWM output channels in total, three of which have complementary PWM outputs with programmable inserted dead-times), a 32-bit and five 16-bit general-purpose PWM timers (up to four PWM output channels), a basic timer, and a 16-bit low-power timer.

HK32ASPIN010xB also incorporates the analog circuitry: a 12-bit ADC (16 analog signal input channels in total, differential pair input supported; sampling rate of up to 1 MSPS), a power-on reset (POR)/power-down reset (PDR) circuit, an internal reference voltage obtained from internal ADC sampling, and a $1/2 V_{BAT}$ voltage divider circuit.

HK32ASPIN010xB integrates the division and square root hardware unit which provides higher performance than software and faster responses to external interrupts.

A hardware unit of motor algorithms is embedded in HK32ASPIN010xB, speeding up the processing of motor drive operations.

HK32ASPIN010xB has four configurable logic units (CLUs) for configurable synchronous and asynchronous Boolean logic operations.

Except for the power pin, ground pin, and NRST pin, all the other pins of HK32ASPIN010xB can be used as GPIOs, peripheral I/Os, or external interrupt inputs. This way, more pin functions can be provided.

HK32ASPIN010xB operates in the -40°C to $+105^{\circ}\text{C}$ temperature range, from a 1.8 V to 3.6 V power supply. It meets the environmental requirements of most applications.

With its wide range of peripherals, HK32ASPIN010xB is suitable for various applications:

- Programmable controllers, printers, and scanners
- Motor-driven devices and speed control
- Internet of Things (IoT) terminals, such as water meters, electricity meters, and gas meters

- Drone control, gimbal control
- Toys
- Household appliances
- Intelligent robots
- Smartwatches and fitness trackers
- Electronic toll collection (ETC)

2.1 Features

- CPU core
 - ARM® Cortex®-M0
 - Maximum frequency: 96 MHz
 - 24-bit SysTick timer
 - Supports the remapping of interrupt vectors (by configuring the Flash controller register)
- Operating voltage range
 - Single power domain (main power supply V_{DD}): 1.8 V to 3.6 V
 - Backup power supply V_{BAT} : 1.8 V to 3.6 V
- Operating temperature range: -40°C to $+105^{\circ}\text{C}$
- Typical operating current
 - Run mode: 6.1 mA@96 MHz; 1.6 mA@8 MHz
 - Sleep mode: 4.7 mA@96 MHz
 - Stop mode:
 - LDO full-speed: 0.7 mA@3.3 V
 - LDO low-power: 60 μA @3.3 V
 - Standby mode: 1.6 μA @3.3 V
 - Shutdown mode: 0.4 μA @3.3 V
- Memory
 - Up to 124 Kbytes of Flash
 - No wait state for Flash access when the CPU frequency is 24 MHz or lower
 - Separate read and write protection for Flash data
 - Encryption for instructions and data stored in the Flash, preventing the damage caused by physical attacks
 - 10-Kbyte SRAM
- Data security
 - CRC hardware implementation unit
- Clock
 - High-speed external clock (HSE): 4 MHz to 32 MHz, typical value: 8 MHz
 - Low-speed external clock (LSE): 32.768 kHz
 - High-speed internal clock (HSI): configurable to 8 MHz/14 MHz/56 MHz
 - Low-speed internal clock (LSI): 40 kHz
 - PLL clock

- Chip pin input clock
- Reset
 - External pin reset
 - POR/PDR
 - Software reset
 - IWDG and WWDG reset
 - Low-power mode reset
- Programmable voltage detector (PVD)
 - Adjustable eight-level thresholds for detecting voltage
 - Rising edge and falling edge detection configurable
- GPIO
 - Up to 55 GPIO pins
 - Each GPIO pin can be used as an external interrupt input
 - Provide the drive current of up to 40 mA
- Data communication interface
 - 2 × USARTs: support synchronous transmission corresponding to SPI master mode and the modem operations. Provide the ISO7816 interface, LIN, IrDA capability, automatic baud rate detection, and the wakeup feature.
 - Up to 2 × high-speed SPIs: support 8-bit to 16-bit programmable data frames, I2S multiplexed.
 - Up to 2 × I2Cs: can operate in fast mode plus (1 Mbit/s) and support SMBus and PMBus. Can wake up the MCU from Stop mode when receiving data.
 - 1 × LPUART: supports asynchronous serial communication, single-wire half-duplex communication, modem operations (CTS/RTS), and multiprocessor communication in the lowest power mode.
 - 1 × CAN: compliant with Specification 2.0A and 2.0B (active).
- Timer and PWM generator
 - 1 × 16-bit advanced timer: with the break function and four PWM outputs in total, three of which have complementary PWM outputs with programmable inserted dead-times
 - 5 × 16-bit and 1 × 32-bit general-purpose timers: TIM2/TIM3/TIM14/TIM15/TIM16/TIM17
 - 1 × 16-bit basic timer: TIM6
 - 1 × low-power timer: LPTIM
- On-chip analog circuitry
 - 1 × 12-bit SAR ADC (up to 16 analog input channels)
 - Maximum frequency: 1 MSPS
 - Supports automatic continuous conversion and scan conversion
 - 3 × voltage comparators
- DMA controller (7-channel)
 - Can be triggered by the timer, ADC, SPI, I2C, or USART
- Temperature sensor
 - The analog output is connected to an independent ADC channel.
- CPU trace and debug
 - SWD debug port
 - ARM® CoreSight™ debug component (ROM-Table, DWT, BPU)

- Customized DBGMCU debug controller (for low-power mode simulation control, debugged peripheral clock control, and debug and trace interfaces allocation)
- Division and square root (DVSQ) calculation unit
 - Supports 32-bit fixed point division, with the quotient and remainder calculated
 - Supports 32-bit fixed point high-precision root calculation
- Four configurable logic units (CLUs) for handling simple logic operations
- Electric motor acceleration (EMACC) hardware unit for faster motor algorithm processing
- RTC
 - Supports the alarm function
 - Periodically wakes up the MCU from Stop or Standby mode
- 96-bit unique ID (UID) of each MCU
- Reliability
 - Passed HBM6000V/CDM2000V/MM200V/LU200mA level tests.

2.2 Device overview

Table 2-1 HK32ASPIN010xB series features

Feature		HK32ASPIN 010FBP6	HK32ASPIN 010GBU6	HK32ASPIN 010KBU6	HK32ASPIN 010KBT6	HK32ASPIN 010CBT6	HK32ASPIN 010RBT6
Operating voltage	Main power supply	1.8 V to 3.6 V					
	Backup power supply	1.8 V to 3.6 V					
Operating temperature		-40°C to +105°C					
Memory	Flash (Kbyte)	124	124	124	124	124	124
	SRAM	10 Kbytes					
CPU	Core	Cortex [®] -M0					
	Frequency	96 MHz					
DMA		7-channel (supports ADC/SPI/I2C/USART/timer)					
DVSQ		1					
Clock	LSI	40 kHz					
	HSI	Configurable to 8 MHz/14 MHz/56 MHz (default: 56 MHz)					
	PLL clock	Supported					
	HSE	8 MHz – 32 MHz					
	LSE	32.768 kHz					
Timer	Advanced timer	TIM1 (16-bit)					
	General-purpose timer	32-bit: TIM2 16-bit: TIM3/TIM14/TIM15/TIM16/TIM17					
	Basic timer	TIM6 (16-bit)					
	Low-power timer	LPTIM (16-bit)					
	SysTick timer	1					
	RTC	1					
	IWDG	1					

Feature		HK32ASPIN 010FBP6	HK32ASPIN 010GBU6	HK32ASPIN 010KBU6	HK32ASPIN 010KBT6	HK32ASPIN 010CBT6	HK32ASPIN 010RBT6
Peripheral communication	WWDG	1					
	USART	2					
	LPUART	1					
	I2C	1	1	2	2	2	2
	SPI/I2S	1	1	1	1	2	2
	CAN (2.0A/2.0B)	1					
ADC	Channels	9	10	10	10	10	16
	Reference selection	External reference voltage input					
	ADC sampling rate	1 MSPS					
	ADC accuracy	12-bit					
EMACC		1					
Voltage comparator		3					
CLU		4					
Info. security	CRC	1					
	96-bit UID	1					
PVD		1					
GPIO		15	23	27	25	39	55
Package Type		TSSOP20	QFN28	QFN32	LQFP32	LQFP48	LQFP64

3 Function description

3.1 Block diagram

ARM® Cortex®-M0 is a 32-bit RISC processor which provides an MCU platform featuring low cost and low power consumption. It delivers outstanding computational performance and advanced system responses to interrupts. With an embedded ARM® Cortex®-M0 core, the HK32ASPINO10xB family is compatible with ARM tools and software.

The block diagram of HK32ASPINO10RBT6 is as follows:

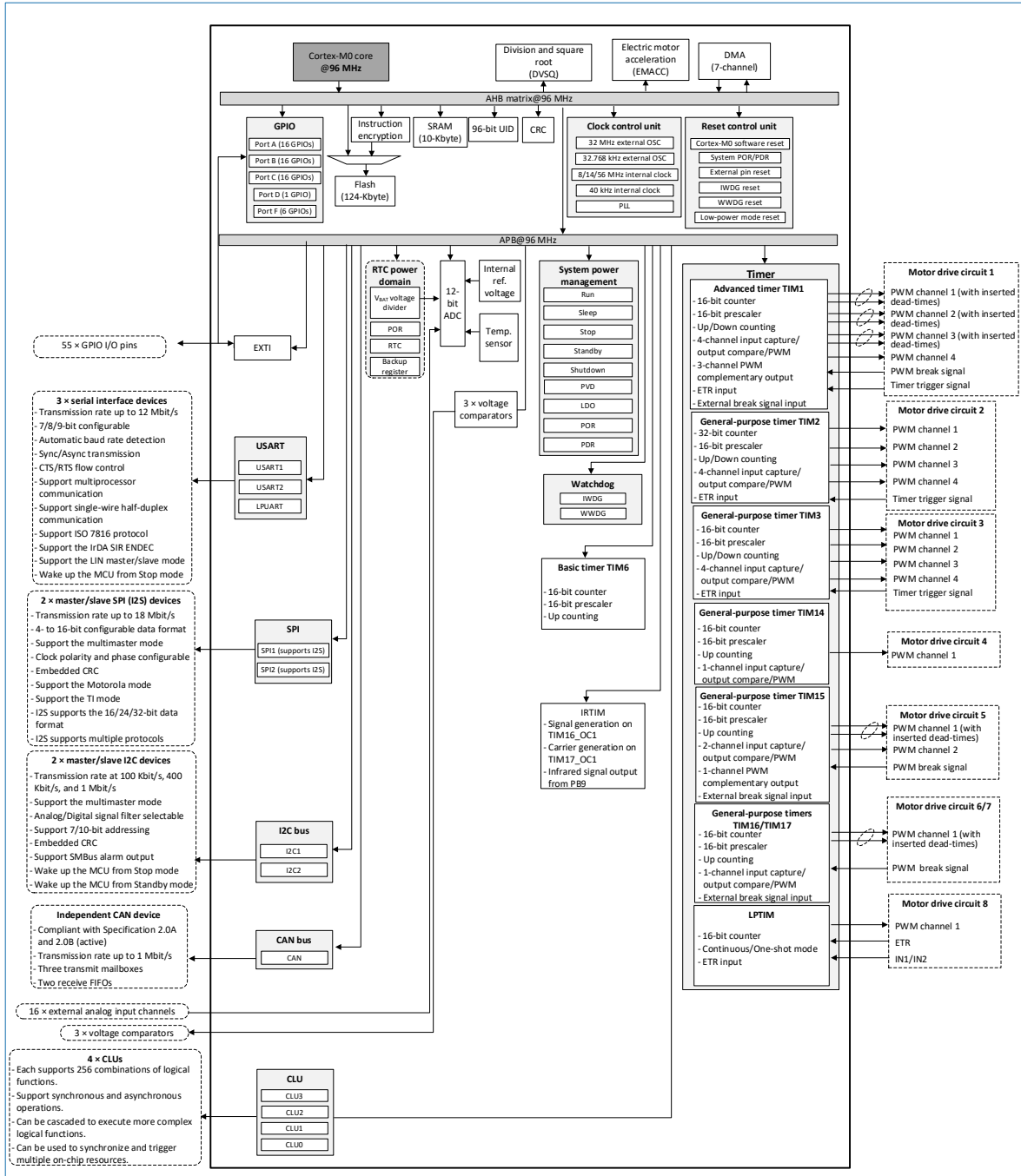

Figure 3-1 HK32ASPINO10RBT6 block diagram

3.2 Memory mapping

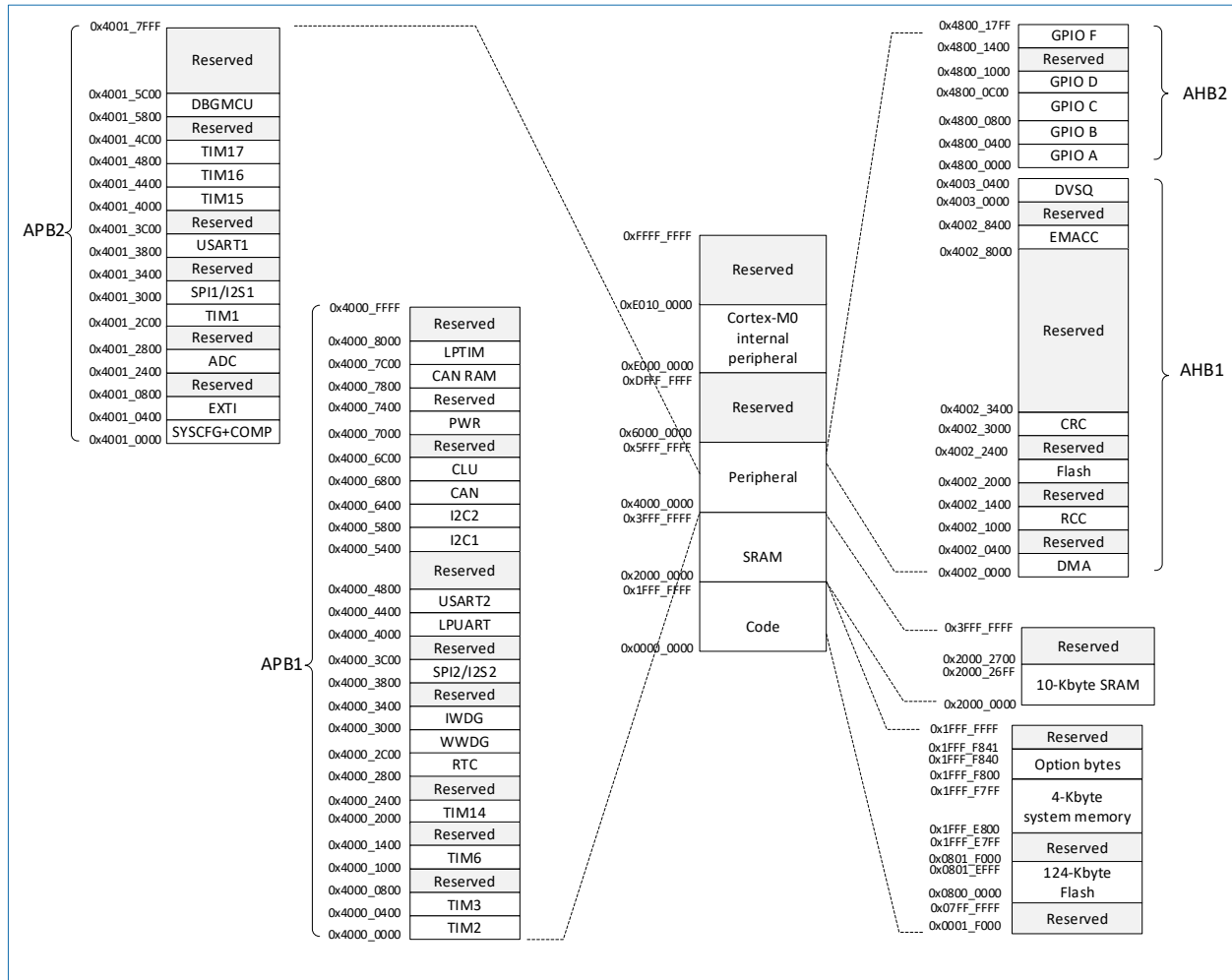

Figure 3-2 HK32ASPIN010RBT6 memory mapping

3.3 Flash

HK32ASPIN010xB integrates a Flash memory of 124 Kbytes to store programs and data.

3.4 SRAM

HK32ASPIN010xB integrates a 10-Kbyte SRAM which can be accessed in words, half words, or bytes. The CPU can access the SRAM with no wait state, meeting the requirements of most applications.

3.5 Resets

3.5.1 System reset

The system reset resets all registers, except for the reset flags in the control/status register `RCC_CSR` and the registers in the backup domain. You can identify the reset source by checking reset status flags in the `RCC_CSR` register.

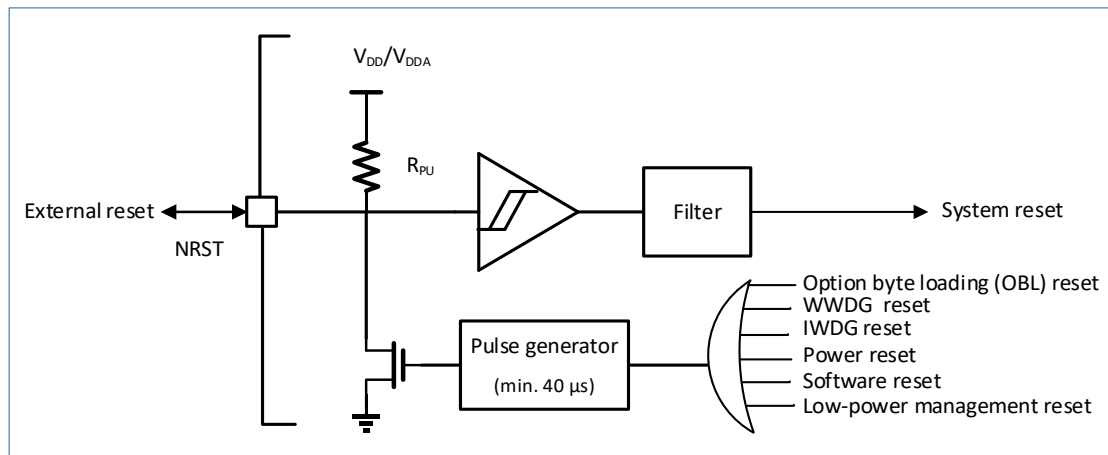

Figure 3-3 Reset signal

A system reset is generated when any of the following events occurs:

- Low level on the NRST pin (external reset)
- Window watchdog counting terminates (WWDG reset)
- Independent watchdog counting terminates (IWDG reset)
- Power reset (POR/PDR)
- Software reset (SW reset): The SYSRESETREQ bit in Cortex[®]-M0 Application Interrupt and Reset Control Register must be set to 1 to force a software reset on the device.
- Low-power management reset
- Option byte loading (OBL) reset

The reset sources finally act on the NRST pin. The NRST pin keeps the low level during resets. The reset routine vector is fixed at address 0x0000 0004.

The internal reset signals are output on the NRST pin. The pulse generator guarantees a reset pulse duration of at least 40 μs for each internal reset source. When the NRST pin is pulled low and an external reset is generated, the reset pulse is generated.

3.5.2 Power reset

A power reset is generated when any of the following events occurs:

- POR/PDR
- Exit from Standby mode

The power reset resets all registers, except for the registers in the backup domain.

HK32ASPIN010xB MCUs contain the POR/PDR circuitry. The circuitry keeps operating to ensure that the system runs properly when the power supply exceeds the 1.8 V threshold. When V_{DD} is less than the POR/PDR threshold, the MCU will be reset without using any external reset circuit.

3.6 Clocks and clock tree

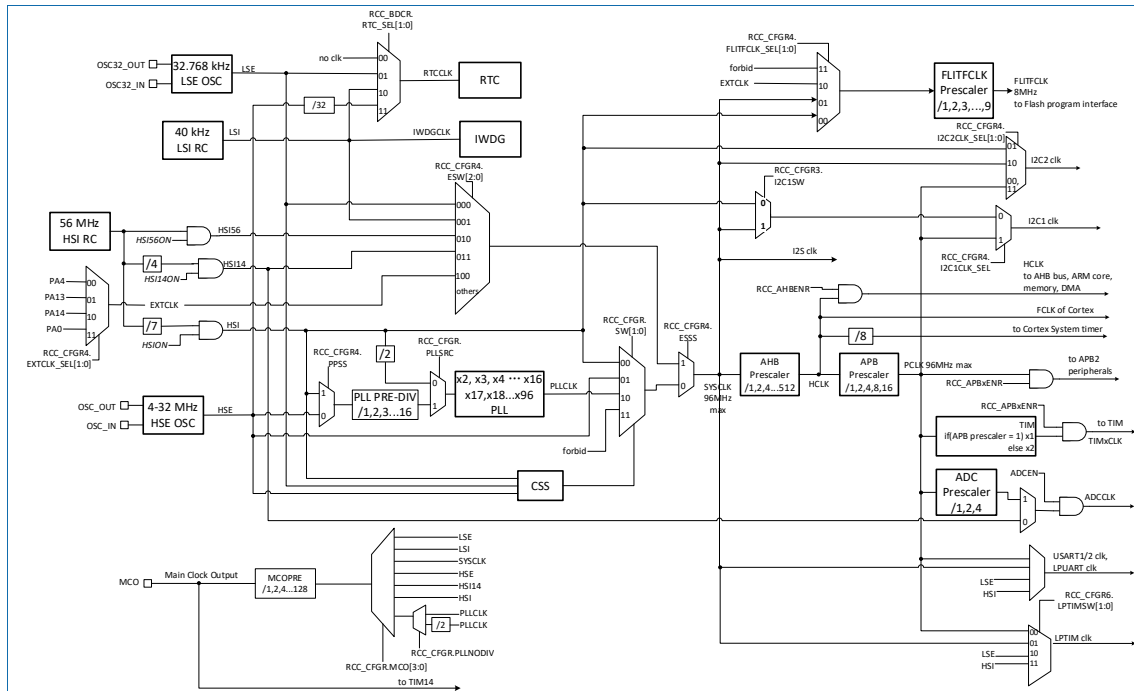

Figure 3-4 Clock tree of HK32ASPINO10xB

As [Figure 3-4](#) shows, HSI and HSI14 are generated by the same internal oscillator operating at 56 MHz. Therefore, when HSI or HSI14 is used, disabling the other clock cannot reduce power consumption. HSI/HSE can be used as the input of the phase-locked loop (PLL) prescaler. You can use HSI together with PLL to configure different system clock frequencies.

HK32ASPINO10xB MCUs use SYSCLK as the CPU clock when they start. The 56 MHz clock output by the internal oscillator, or the prescaled HSI or HSI14 can be used as the SYSCLK.

HK32ASPINO10xB provides more clock sources for the system clock and offers convenient, flexible, and diverse operating modes to customers. The following clocks can act as the system clock:

- 56 MHz HSI
- HSE
- PLL clock
- 14 MHz HSI14
- 8 MHz HSI
- 40 kHz LSI, which can drive the IWDG or be used as the RTC to automatically wake up the MCU from Stop/Standby mode
- 32.768 kHz LSE, which can drive the RTCCLK

In addition, PCLK can act as the I2C clock source.

3.7 Power supply scheme

- $V_{DD} = 1.8\text{ V to }3.6\text{ V}$. The V_{DD} pin supplies power to I/O pins and the internal low dropout regulators (LDOs).
- $V_{DDA} = 1.8\text{ V to }3.6\text{ V}$. The V_{DDA} pin supplies power to the analog circuitry, such as the ADC and temperature sensor.
- $V_{BAT} = 1.8\text{ V to }3.6\text{ V}$. When V_{DD} is powered off, V_{BAT} supplies power to the RTC, external 32.768 kHz oscillator, and backup registers.

3.8 Boot modes

The Boot0 pin and its configuration bit are used to select the system boot mode:

- Boot from Flash memory
- Boot from system memory
- Boot from internal SRAM

The bootloader program is stored in the system memory. The bootloader program can reprogram the Flash via the USART1 PA9/PA10 pin or USART2 PA14/PA15 pin.

3.9 PVD

HK32ASPIN010xB integrates a programmable voltage detector (PVD). The PVD monitors V_{DD} and compares it with the V_{PVD} threshold. When V_{DD} is below or over the V_{PVD} threshold, an interrupt is generated, and the interrupt program may send a warning message or set the MCU in the safe state. The PVD is enabled by setting the register.

3.10 Low-power modes

HK32ASPIN010xB supports multiple power consumption modes.

- **Run mode**
In Run mode, the CPU runs at full speed.
- **Sleep mode**
In Sleep mode, only the CPU stops. All peripherals keep operating. The CPU can be woken up when an interrupt or event occurs.
- **Stop mode**
In Stop mode, MCUs achieve the lowest power consumption while retaining the content in SRAM and registers. In Stop mode, all clocks in the core domain, the HSI RC oscillator, and the HSE crystal oscillator are disabled. MCUs can be woken up from Stop mode by any EXTI line. The EXTI line source can be any of the 16 external I/O pins, a PVD output, or an RTC alarm signal.
- **Standby mode**
In Standby mode, the MCU achieves the lowest power consumption. The internal LDO is off, so the entire 1.2 V domain is powered off. The PLL, HSI RC oscillator, and HSE crystal oscillator are disabled. The SRAM and register content is lost, except for registers in the backup domain. The Standby circuitry works as normal. MCUs exit from Standby mode when an external reset on the NRST pin, an IWDG reset, a rising edge on the WKUP pin, or an RTC alarm occurs.
- **Shutdown mode**
In Shutdown mode, the MCU achieves extremely low power consumption as in Standby mode. All internal LDO power supplies (including the power supply of the backup domain) and all clock sources are off, except for the shutdown wakeup circuitry. MCUs exit from Shutdown mode when an external reset on the NRST pin, an IWDG reset, or a rising edge on the WKUP pin occurs. The backup domain is off, so the MCU cannot be woken up by an RTC alarm.

Table 3-1 Operating modes and power consumption

Operating Mode	Power Consumption	Wakeup Time
Run mode	Power consumption 1.6 mA/8 MHz@3.3 V	-
Sleep mode	Power consumption 1.3 mA/8 MHz@3.3 V	4.7 μ s
Stop mode	Static power consumption 60 μ A@3.3 V	132 μ s (fastest speed)
Standby mode	Static power consumption 1.6 μ A@3.3 V	152 μ s
Shutdown mode	Lowest static power consumption 0.4 μ A@3.3 V	364 μ s

The conditions for entering and exiting low-power modes are listed in the following table:

Table 3-2 Conditions for entering and exiting low-power modes

Operating Mode	Entry	Exit
Sleep mode	<ol style="list-style-type: none"> 1. Set PWR_CR:LPDS = 0. 2. The software executes WFI/WFE instructions. 	Any IRQ interrupt/event, including the SysTick timer.
Stop mode	<ol style="list-style-type: none"> 1. Set PWR_CR:PDDS = 0. 2. Set the SLEEPDEEP bit in the Cortex-M0 system control register. The software executes WFI/WFE instructions. 	Any EXTI line.
Standby mode	<ol style="list-style-type: none"> 1. Set PWR_CR:LPDS = 0. 2. Set PWR_CR:PDDS = 1. 3. Set the SLEEPDEEP bit in the Cortex-M0 system control register. 4. The software executes WFI/WFE instructions. 	Three polarity-configurable external pins, or the RTC alarm.
Shutdown mode	<ol style="list-style-type: none"> 1. Set PWR_CR:LPDS = 0. 2. Set PWR_CR:PDDS = 1. 3. Set PWR_CSR2:SHDS = 1. 4. Set the SLEEPDEEP bit in the Cortex-M0 system control register. 5. The software executes WFI/WFE instructions. 	Three polarity-configurable external pins.

3.11 NVIC

HK32ASPIN010xB incorporates the nested vectored interrupt controller (NVIC). NVIC can flexibly manage up to 32 maskable interrupt channels (including 16 Cortex[®]-M0 interrupt lines) and four interrupt priorities while maintaining the lowest interrupt latency.

- The closely coupled NVIC ensures low latency during interrupt processing.
- The interrupt vector entry address is directly passed to the core.
- Provides the closely coupled NVIC interface.
- Supports the early processing of interrupts.
- Processes higher-priority interrupts even if they arrive late.
- Supports tail-chaining.
- Saves the processor state automatically.
- The previous state is resumed upon interrupt exit with no extra instruction needed.

Table 3-3 NVIC

Position	Priority	Name	Description	Address	
-	-	-	-	Reserved	0x0000_0000
-	-3	Fixed	Reset	Reset	0x0000_0004
-	-2	Fixed	NMI	Non-maskable interrupt. The RCC clock security system (CSS) is connected to the NMI vector.	0x0000_0008
-	-1	Fixed	HardFault	All classes of faults	0x0000_000C
-	3	Configurable	SVCall	System service call via SWI instruction	0x0000_002C
-	5	Configurable	PendSV	Pendable request for system service	0x0000_0038
-	6	Configurable	SysTick	SysTick timer	0x0000_003C
0	7	Configurable	WWDG	Window watchdog interrupt	0x0000_0040
1	8	Configurable	PVD	PVD interrupt (through EXTI line 16)	0x0000_0044
2	9	Configurable	RTC	RTC interrupt (through EXTI line 17, 19, and 20)	0x0000_0048
3	10	Configurable	Flash	Flash global interrupt	0x0000_004C
4	11	Configurable	RCC	RCC global interrupt	0x0000_0050

Position	Priority		Name	Description	Address
5	12	Configurable	EXTI0_1	EXTI Line[1:0] interrupts	0x0000_0054
6	13	Configurable	EXTI2_3	EXTI Line[3:2] interrupts	0x0000_0058
7	14	Configurable	EXTI4_15	EXTI Line[15:4] interrupts	0x0000_005C
8	15	Configurable	LPUART_IRQ	LPUART interrupt (through EXTI line 28)	0x0000_0060
9	16	Configurable	DMA_CH1	DMA channel 1 global interrupt	0x0000_0064
10	17	Configurable	DMA_CH2_3	DMA channel 2/3 interrupt	0x0000_0068
11	18	Configurable	DMA_CH4_7	DMA channel 4/5/6/7 interrupt	0x0000_006C
12	19	Configurable	ADC	ADC interrupt (through EXTI line 21, 22, 30, and 31)	0x0000_0070
13	20	Configurable	TIM1_BRK_UP_TRG_COM	TIM1 break, update, trigger, and commutation interrupt	0x0000_0074
14	21	Configurable	TIM1_CC	TIM1 capture/compare interrupt	0x0000_0078
15	22	Configurable	TIM2	TIM2 global interrupt	0x0000_007C
16	23	Configurable	TIM3	TIM3 global interrupt	0x0000_0080
17	24	Configurable	TIM6	TIM6 global interrupt	0x0000_0084
18	25	Configurable	LPTIM	LPTIM global interrupt (through EXTI line 29)	0x0000_0088
19	26	Configurable	TIM14	TIM14 global interrupt (through EXTI line 32 connected to CLU0)	0x0000_008C
20	27	Configurable	TIM15	TIM15 global interrupt	0x0000_0090
21	28	Configurable	TIM16	TIM16 global interrupt (through EXTI line 33 connected to CLU1)	0x0000_0094
22	29	Configurable	TIM17	TIM17 global interrupt	0x0000_0098
23	30	Configurable	I2C1	I2C1 global interrupt (through EXTI line 23)	0x0000_009C
24	31	Configurable	I2C2	I2C2 global interrupt (through EXTI line 24)	0x0000_00A0
25	32	Configurable	SPI1	SPI1 global interrupt (through EXTI line 34 connected to CLU2)	0x0000_00A4
26	33	Configurable	SPI2	SPI2 global interrupt (through EXTI line 35 connected to CLU3)	0x0000_00A8
27	34	Configurable	USART1	USART1 global interrupt (through EXTI line 25)	0x0000_00AC
28	35	Configurable	USART2	USART2 global interrupt (through EXTI line 26)	0x0000_00B0
29	36	Configurable	Reserved	-	0x0000_00B4
30	37	Configurable	CAN	CAN global interrupt	0x0000_00B8
31	38	Configurable	DVSQ	DVSQ global interrupt	0x0000_00BC

3.12 EXTI

The extended interrupt/event controller (EXTI) manages 34 interrupt lines that are used to generate interrupt/event requests and wake up the system through edge detection. The trigger event of each EXTI line can be configured and masked independently. The trigger event can be a rising edge, a falling edge, or both. The pending register stores the status of each interrupt request. EXTI can detect external interrupt line signals whose pulse width is shorter than the internal clock period. Up to 55 GPIOs can be connected to up to 16 external interrupt lines.

The EXTI lines from EXTI 0 to EXTI 15 are connected to I/O pins. The connections of the other EXTI lines are as follows:

- EXTI 16 connected to the PVD output
- EXTI 17 connected to the RTC alarm event
- EXTI 19 connected to the RTC tamper detection and timestamp event

- EXTI 20 connected to the RTC wakeup event
- EXTI 21 connected to the Comp1 output
- EXTI 22 connected to the Comp2 output
- EXTI 23 connected to the I2C1 wakeup event
- EXTI 24 connected to the I2C2 wakeup event
- EXTI 25 connected to the USART1 wakeup event
- EXTI 26 connected to the USART2 wakeup event
- EXTI 28 connected to the LPUART wakeup event
- EXTI 29 connected to the LPTIM wakeup event
- EXTI 30 connected to the Comp3 output
- EXTI 31 connected to the ADC AWD event
- EXTI 32 connected to the CLU0 output
- EXTI 33 connected to the CLU1 output
- EXTI 34 connected to the CLU2 output
- EXTI 35 connected to the CLU3 output

EXTI lines from EXTI 23 to EXTI 26, from EXTI 28 to EXTI 29, and EXTI 31 are connected to internal events and do not have the rising trigger selection register (RTSR), falling trigger selection register (FTSR), software interrupt event register (SWIER), and pending register (PR). These EXTI lines detect the rising edge of events in only Stop mode and generate the event request (ERQ) and interrupt request (IRQ) to wake up the system. The corresponding interrupt control bit and status bit are stored in the peripheral from which events are generated.

3.13 IWDG

The independent watchdog (IWDG) is based on a 12-bit downcounter and an 8-bit prescaler. The IWDG is clocked by an internal independent 40 kHz RC oscillator. The RC oscillator is independent of the main clock, so it can operate in Stop mode and Standby mode. The IWDG can work as a watchdog to reset the system when a problem occurs or as a free-running timer that provides timeout management for applications. The IWDG can be started by hardware or software through the configuration of the option bytes. In debug mode, the counter can be frozen.

You can set the IWDG_WINR register to use IWDG in window mode.

3.14 WWDG

The window watchdog (WWDG) is based on an internal 7-bit downcounter. The counter can be set to the free running mode or used as a watchdog to reset the system when the system crashes. The WWDG is clocked by the main clock and has the early warning interrupt function. In debug mode, the counter can be frozen.

3.15 SysTick timer

The SysTick timer is a dedicated standard downcounter for the operating system. Its features include:

- 24-bit downcounter
- Auto-reload capability
- Generates a maskable interrupt when the counter reaches 0
- Programmable clock source

3.16 Timers

Each HK32ASPIN010xB MCU has an advanced timer, six general-purpose timers, a basic timer, and a low-power timer. The features of the timers are listed in the following table.

Table 3-4 Features of the timers

Type	Timer	Counter Resolution	Counter Type	Prescaler Factor	DMA Request	Break Input	Capture/Compare Channels	Complementary Outputs
Advanced timer	TIM1	16-bit	Up, down, up/down	0 – 0xFFFF	Yes	Yes	4	3
General-purpose timer	TIM2	32-bit	Up, down, up/down	0 – 0xFFFF	Yes	No	4	No
	TIM3	16-bit	Up, down, up/down	0 – 0xFFFF	Yes	No	4	No
	TIM14	16-bit	Up	0 – 0xFFFF	No	No	1	No
	TIM15	16-bit	Up	0 – 0xFFFF	Yes	Yes	2	1
	TIM16	16-bit	Up	0 – 0xFFFF	Yes	Yes	1	1
	TIM17	16-bit	Up	0 – 0xFFFF	Yes	Yes	1	1
Basic timer	TIM6	16-bit	Up	0 – 0xFFFF	Yes	No	No	No
Low-power timer	LPTIM	16-bit	Up	1/2/4/...../128	No	No	1	No

3.16.1 Basic timer

HK32ASPIN010xB integrates a basic timer TIM6.

TIM6 embeds a 16-bit upcounter and a 16-bit prescaler.

3.16.2 General-purpose timer

HK32ASPIN010xB integrates six general-purpose timers.

- TIM2 and TIM3

TIM2 is based on a 32-bit auto-reload up/down counter and a 16-bit prescaler. TIM3 is based on a 16-bit auto-reload up/down counter and a 16-bit prescaler. TIM2 and TIM3 have four independent channels respectively. The channels can be used for input capture, output compare, PWM output, and one-pulse mode output. In the LQFP64 package, up to 12 channels are available for input capture, output compare, and PWM output.

TIM2 and TIM3 can work with advanced timer TIM1 through the Timer Link feature for synchronization and event chaining. TIM2 and TIM3 can generate independent DMA requests. TIM2 and TIM3 can process quadrature (incremental) encoder signals and the digital outputs from one to three hall-effect sensors. In debug mode, the counter can be frozen.

- TIM14 and TIM15

TIM14 and TIM15 are based on a 16-bit auto-reload upcounter and a 16-bit prescaler respectively. TIM14 has one channel for input capture, output compare, PWM output, and one-pulse mode output. TIM15 has two channels, one of which is for complementary output. In debug mode, the counter can be frozen. TIM15 can generate DMA requests but TIM14 cannot.

- TIM16 and TIM17

TIM16 and TIM17 are based on a 16-bit auto-reload upcounter and a 16-bit prescaler respectively. TIM16 and TIM17 have a channel respectively for input capture, output compare, PWM output, and one-pulse mode output. TIM16 and TIM17 both have complementary outputs with programmable inserted dead-times and can generate independent DMA requests. In debug mode, the counter can be frozen.

3.16.3 Advanced timer

HK32ASPIN010xB integrates an advanced timer TIM1.

TIM1 can be deemed as a three-phase PWM generator with six channels or used as a complete general-purpose timer. The four independent channels of TIM1 can be used for:

- Input capture
- Output compare
- PWM generation (edge- or center-aligned mode)
- One-pulse mode output
- Three of the four channels have complementary PWM outputs with programmable inserted dead-times.

If TIM1 is configured as a 16-bit basic timer, it has the same functions as a basic timer. If the advanced timer is configured as a 16-bit PWM generator, it has full modulation capability (0–100%). Many functions of TIM1 are the same as those of general-purpose timers. Therefore, the advanced timer can work together with general-purpose timers through the Timer Link feature for synchronization or event chaining.

In debug mode, the counter can be frozen.

3.16.4 Low-power timer

HK32ASPINO10xB has a 16-bit low-power timer LPTIM.

LPTIM can work in Sleep mode and Stop mode. If no internal clock source is available, LPTIM can provide the pulse counter function. LPTIM can wake up the system from low-power modes.

The flexible clock schemes provided by LPTIM can minimize the power consumption of the system.

LPTIM has the following functions:

16-bit upcounter

Prescaler (1/2/4/8/16/32/64/128)

Clock sources for selection

16-bit auto-reload register

16-bit compare register

Continuous/One-shot mode

Software/Hardware input trigger configurable

Programmable digital filter

Configurable output

3.17 IRTIM

An infrared interface (IRTIM) is embedded in each HK32ASPINO10xB MCU. The IRTIM works with infrared LEDs to provide the remote control function. To generate infrared remote control signals, you must enable the IRTIM (PB9) and configure TIM16 channel 1 (TIM16_OC1) and TIM17 channel 1 (TIM17_OC1).

The infrared receiver function can be implemented by setting TIM16 channel 1 and TIM17 channel 1 to the basic input capture mode.

3.18 I2C

Up to two I2C bus interfaces are embedded in HK32ASPINO10xB MCUs. Each I2C bus interface has an output drive of 30 mA and can operate in master or slave mode at one of the following speeds:

- Standard mode (up to 100 Kbit/s)
- Fast mode (up to 400 Kbit/s)
- Fast mode plus (up to 1 Mbit/s)

The I2C bus interfaces support the 7-bit or 10-bit addressing mode and 7-bit dual addressing mode (as slave). The I2C interfaces embed hardware CRC generation/verification.

The I2C interfaces are compatible with SMBus 2.0 and PMBus 1.1. The address resolution protocol (ARP) capability, host notify protocol, hardware CRC (packet error checking, PEC) generation/verification, timeout verification, and alert protocol management are supported.

The I2C interfaces also have a clock independent of the CPU clock domain, so they can wake up the MCU from Stop mode when the address is matched.

The I2C interfaces have an analog filter and a digital filter. The following table lists the features of the filters:

Table 3-5 Programmable analog noise filter and digital noise filter

	Analog Filter	Digital Filter
Suppressed pulse width	≥ 50 ns	Programmable length from 1 to 15 I2C peripheral clock periods
Advantage	Available in Stop mode	<ul style="list-style-type: none"> Extra filtering capability, standard requirements Stable programmable length
Disadvantage	Performance changes along with the temperature, voltage, and process	When the digital filter is enabled, I2C cannot wake up the MCU from Stop mode even if the address is matched.

3.19 USART

Two universal synchronous/asynchronous receivers/transmitters (USART1 and USART2) are embedded in each HK32ASPIN010xB MCU. They can communicate at up to 12 Mbit/s.

The USARTs provide hardware management for the CTS, RTS, and RS485 DE signals. The USARTs support the multiprocessor communication mode, host synchronous communication mode, and single-wire half-duplex communication mode. The USARTs also support Smart Card communication (ISO 7816), IrDA SIR ENDEC, LIN master/slave capability, and automatic baud rate detection. The USARTs can be served by the DMA controller.

The USARTs have a clock independent of the CPU clock domain, so they can wake up the MCU from Stop mode.

Table 3-6 USART1/USART2 features

Feature	USART1/USART2
Modem hardware flow control	Supported
DMA continuous transmission	Supported
Multiprocessor communication	Supported
Synchronous mode	Supported
Smart Card mode	Supported
Single-wire half-duplex communication	Supported
IrDA SIR ENDEC	Supported
LIN mode	Supported
Dual clock domains and wakeup from Stop mode	Supported
Receiver timeout interrupt	Supported
Modbus communication	Supported
Automatic baud rate detection	Supported
Driver enable	Supported

3.20 LPUART

HK32ASPIN010xB incorporates a low-power universal asynchronous receiver/transmitter (LPUART) which can communicate at up to 10 Mbit/s. The LPUART supports asynchronous serial communication, single-wire half-duplex communication, and modem operations (CTS/RTS) in low-power mode. It also supports multiprocessor communication.

The LPUART has a clock independent of the CPU clock domain. It can wake up the MCU from Stop mode at a baud rate of up to 4.8 Kbit/s when any of the following events occurs:

- Start bit detection event
- Interrupt of receiving any data frame

- Receiving specific programming data frame

When using the 32.768 kHz LSE, the LPUART can communicate at up to 9600 baud. In Stop mode, the LPUART waits for incoming frames at extremely low power consumption. If the LPUART uses a faster clock, it can communicate at a higher baud rate.

The LPUART can be served by the DMA controller.

3.21 SPI/I2S

Up to two SPI interfaces operating at up to 18 Mbit/s are embedded in HK32ASPIN010xB MCUs. The SPI interfaces support master and slave modes and full-duplex or half-duplex communication. The 3-bit prescaler generates eight frequencies of master mode. Each frame can be configured to 4- to 16-bit.

Table 3-7 SPI1/SPI2 features

SPI Feature	SPI1/SPI2
Hardware CRC calculation	Supported
RX/TX FIFO	Supported
NSS pulse mode	Supported
I2S mode	Supported
TI mode	Supported

The standard I2S interfaces (with SPI multiplexed) provide four types of audio standards and can operate in master/slave half-duplex communication mode. The I2S interfaces have dedicated signals for data synchronization. The data format can be 16-bit, 24-bit, or 32-bit and the I2S interfaces can operate with 16- or 32-bit resolution. The I2S interfaces can be set to an audio sampling frequency from 8 kHz to 192 kHz by the 8-bit programmable linear prescaler. When working in master mode, the I2S interface can output a clock of 256 times the sampling frequency to external audio components.

Table 3-8 I2S features

I2S Feature	I2S
Half-duplex mode	Supported
Master/Slave mode configurable	Supported
8-bit programmable linear prescaler	Supported
Data format programmable	Supported
Clock polarity programmable	Supported
I2S protocol	Supported
DMA transmission	Supported
Driving external audio components	Supported

3.22 GPIO

Each GPIO pin can be configured as an output pin (push-pull or open-drain), an input pin (floating, pull-up, or pull-down), or a peripheral alternate function pin by using the software. Most of the GPIO pins are shared by digital and analog peripherals. All GPIOs are high current capable. I/O alternate functions can be locked as needed to avoid unexpected writes to the I/O registers.

3.23 DMA

The 7-channel general-purpose DMA controller manages the data transfer from memories to memories, from devices to memories, and from memories to devices. The DMA controller supports circular buffer management, preventing the interrupt that occurs when the DMA controller reaches the end of the buffer.

Each channel is connected to a dedicated hardware DMA request and can be triggered by using the software. The length, source, and destination of data to be transferred can be independently set by using the software. DMA can be used with the main peripherals, such as SPI, I2C, USART, TIMx, SDIO, and ADC.

3.24 ADC

The 12-bit analog-to-digital converter (ADC) has the following functions:

- Up to 16 external channels and three internal channels (temperature sensor, reference voltage, and V_{BAT})
- Performs A/D conversion in single-channel or multi-channel scan mode. In scan mode, the conversion is automatically performed on a selected group of analog inputs.
- Can be served by the DMA controller
- Supports the sampling of $1/2 V_{BAT}$
- Can be triggered by external trigger sources

The analog watchdog function can realize precise monitoring of one, some, or all selected channels. If the converted voltage exceeds the threshold set by the program, an interrupt is generated.

3.25 CAN

The CAN interface is compliant with Specification 2.0A and 2.0B (active). The highest bit rate is 1 Mbit/s. The CAN interface can receive and transmit standard frames with 11-bit identifiers as well as extended frames with 29-bit identifiers. The CAN interface has three transmit mailboxes and two 3-stage receive FIFOs. Each FIFO has 14 scalable filters.

3.26 RTC clock

In all operating modes of HK32ASPIN010xB (including the Standby mode), a real-time clock (RTC) and five backup registers are provided. The backup registers are 32-bit registers. They are used to store 20 bytes of user application data. The system reset and wakeup from the Standby mode do not reset backup registers.

The RTC has programmable periodic wakeup flags with the interrupt function.

The digital calibration feature compensates for deviation in the crystal oscillator accuracy.

After the RTC domain is reset, unexpected writes to all RTC registers are prevented.

As long as the power supply voltage of the MCU is within the operating range, the RTC keeps working in all modes of the MCU.

The RTC is an independent binary-coded decimal (BCD) timer/counter. It has the following features:

- Calendar with sub-seconds, seconds, minutes, hours (12- or 24-hour format), day of the week, day of the month, month, and year in BCD
- Automatic adjustment to the days of different months: 28 days, 29 days (leap year), 30 days, and 31 days. The adjustment for daylight saving time is also supported.
- Two programmable alarms that can wake up the MCU from Stop or Standby mode
- Programmable resolution and periodic wakeup from Stop or Standby mode
- Correction of 1 to 32,767 RTC clock pulses during runtime for synchronization between RTC and the main clock
- Reference clock detection: a more accurate secondary clock source (50 Hz or 60 Hz) that can improve calendar accuracy
- Digital calibration circuit with 1 ppm resolution for compensation of deviation in the crystal oscillator accuracy
- Two tamper detection pins with programmable filters. Wakeup from Stop or Standby mode when any tamper event is detected
- Timestamp feature used for storage of calendar content. The timestamp feature can be triggered by the event on the timestamp pin or by the tamper event. MCUs can be woken up from Stop or Standby mode when any timestamp event is detected.

The RTC clock source can be:

- 32.768 kHz external crystal oscillator
- Low-power internal RC oscillator (typical frequency: 40 kHz)
- HSE divided by 32

3.27 CRC calculation unit

The cyclic redundancy check (CRC) is used to verify the integrity of data during transmission and storage. HK32ASPIN010xB integrates a CRC hardware calculation unit. It is used to get a CRC code from an 8-, 16- or 32-bit data word by using a generator polynomial.

The CRC calculation unit computes a signature of the software during runtime. This signature is to be compared with a reference signature, which is generated at link time and stored at a specified memory location.

3.28 EMACC

The Electric Motor Acceleration (EMACC) unit can be used on brushless direct current (BLDC) motors controlled by the field-oriented control (FOC) algorithm. EMACC accelerates the mathematical operations of motor drives. Mathematical operations can be completed at a speed higher than that of software-based mathematical operations while occupying less CPU resources. The EMACC-embedded MCUs support higher motor rotation speeds under the same CPU frequency.

The coordinate rotation digital computer (CORDIC) algorithm, Clarke, Park, and Inverse Park transformations, and proportional-integral-derivative (PID) control of the FOC algorithm are implemented by hardware, which reduces CPU usage and speeds up computing. Users input three-phase currents I_a , I_b , and I_c . After the processing by EMACC, the input U_α and U_β of space vector pulse width modulation (SVPWM) can be obtained. EMACC decreases the time consumed by the FOC algorithm.

EMACC can significantly increase algorithm efficiency.

3.29 DVSQ calculation unit

The division and square root (DVSQ) calculation unit has the following features:

- Supports the 32-bit signed integer division (SDIV), unsigned integer division (UDIV), and root calculation.
 - The DVSQ calculation unit supports either the division or root calculation at one time.
 - The quotient and remainder of 32-bit SDIV and UDIV are updated to the corresponding register.
 - The MOD operation is supported in the division.
- High-precision root calculation can be selected for unsigned integer root calculation by using the software.
- In the streamlined design, a 2-bit calculation is completed in each clock period.
- The calculation time varies based on the calculation data.
- Supports divide-by-zero interrupt and overflow interrupt.

3.30 CLU

HK32ASPIN010xB embeds a configurable logic module (CLM). The CLM offers several programmable digital logic blocks which can operate without using the CPU resource. The CLM consists of four dedicated configurable logic units (CLUs) for programmable synchronous and asynchronous Boolean logic operations. The input of each CLU can be an internal or external signal, and the output of each CLU can be connected to an I/O pin or the input of a specified peripheral.

The CLU has the following features:

- Each CLU supports 65,536 combinations of logical functions, such as AND, OR, XOR, or multiplexing, and has a clock trigger used for synchronization.

- Synchronous and asynchronous operations are supported.
- CLUs can be cascaded to realize more complex logical functions.
- CLUs can be used in conjunction with timers or serial peripherals such as UART and SPI.
- CLUs can be used to synchronize and trigger multiple on-chip resources (such as ADC and timers).
- The output of asynchronous operations can be used to wake up the MCU from low-power modes.

3.31 Voltage comparator

HK32ASPIN010xB has three built-in voltage comparators: COMP1, COMP2, and COMP3. The three comparators can be used as independent window comparators or used together.

3.32 Internal reference voltage

The internal reference voltage V_{REFINT} provides a stable voltage output for the ADC and comparators. V_{REFINT} is internally connected to the ADC_IN17 input channel. The V_{REFINT} memory address can only be read.

Table 3-9 Internal voltage benchmark value

Value Name	Description	Memory Address
V_{REFINT_CAL}	The original data obtained under 25°C temperature. $V_{DDA} = 3.3\text{ V}$ ($\pm 10\text{ mV}$)	0x1FFF F7BA-0x1FFF F7BB

3.33 Temperature sensor

The temperature sensor generates a voltage that varies linearly based on the temperature. The temperature sensor is internally connected to the ADC1_IN16 input channel which is used to convert the sensor output voltage into a digital value.

The temperature sensor is accurate, but it still needs to be calibrated to ensure the accuracy of overall temperature measurement. The temperature sensor offset of different MCUs varies based on the manufacturing processes of the MCUs. Therefore, uncalibrated temperature sensors are suited only for applications that measure temperature changes. All HK32ASPIN010xB MCUs are factory-calibrated to guarantee the measurement accuracy of the temperature sensors. The factory calibration data of temperature sensors is stored in the system memory and can only be read.

3.34 96-bit UID

The 96-bit unique identifier (UID) provides a reference number for each HK32ASPIN010xB MCU. The UID is unique in any circumstances. You are not allowed to modify the UID. The 96-bit UID can be read in bytes (8 bits), half words (16 bits), or words (32 bits) for different applications. The 96-bit UID can be used:

- As a serial number. For example, as a USB string serial number or used for other terminal applications.
- As a security key. When programming the Flash, use the UID together with software encryption and decryption algorithms to enhance the security of code in the Flash.
- To activate the boot processes that have the security mechanism.

3.35 Debug port

Based on the ARM SWJ-DP embedded in HK32ASPIN010xB, SWDIO/SWCLK functions are available.

4 Electrical characteristics

4.1 Absolute maximum values

The absolute maximum values are stress test values within a short period.

Note:

- Do not use the device in conditions equal to or exceeding the absolute maximum values.
- Stresses beyond the absolute maximum values listed in [Table 4-1](#) to [Table 4-26](#) may cause permanent damage to the device.
- If the device works under the maximum values for extended periods, its reliability may deteriorate.

4.1.1 Voltage characteristics

Table 4-1 Voltage characteristics

Symbol	Description	Min	Max	Unit
$V_{DD} - V_{SS}$	External main power supply voltage (including V_{DDA} and V_{DD})	-0.3	3.75	V
V_{IN}	Input voltage on pins	$V_{SS} - 0.3$	V_{DD}	
$ \Delta V_{DDX} $	Variation between different power pins	-	50	mV
$ V_{SSX} - V_{SS} $	Variation between different ground pins	-	50	

4.1.2 Current characteristics

Table 4-2 Current characteristics

Symbol	Description	Max	Unit
I_{VDD}	Total current into V_{DD}/V_{DDA} (source) ⁽¹⁾	100	mA
I_{VSS}	Total current from V_{SS} (sink) ⁽¹⁾	-100	
I_{IO}	Output current sunk by any I/O and control pin	20	
	Output current sourced by any I/O and control pin	-40	
$I_{INJ(PIN)}^{(2)}$	Injected current on pins ⁽³⁾	±5	
$\Sigma I_{INJ(PIN)}$	Total injected current (all I/Os and control pins) ⁽⁴⁾	±25	

- (1). All main power (V_{DD} , V_{DDA}) and ground (V_{SS} , V_{SSA}) pins must be connected to the external power supply within the permitted range all the time.
- (2). Negative injected current causes the analog performance of the device to fluctuate.
- (3). When V_{IN} is larger than V_{DD} , a positive injected current is induced; when V_{IN} is smaller than V_{SS} , a negative injected current is induced. The injected current must be within the permitted range.
- (4). If multiple I/Os have current injection simultaneously, the maximum $\Sigma I_{INJ(PIN)}$ is the sum of the absolute instantaneous values of positive and negative injected currents.

4.1.3 Temperature characteristics

Table 4-3 Temperature characteristics

Symbol	Description	Value	Unit
T_{STG}	Storage temperature range	-45 to +125	°C
T_J	Maximum junction temperature	125	

4.2 Operating conditions

4.2.1 Recommended operating conditions

Table 4-4 Recommended operating conditions

Symbol	Description	Min	Max	Unit
f_{HCLK}	Internal AHB clock frequency	0	96	MHz
f_{PCLK1}	Internal APB1 clock frequency	0	96	
f_{PCLK2}	Internal APB2 clock frequency	0	96	

Symbol	Description	Min	Max	Unit
V _{DD}	Standard operating voltage	1.8	3.6	V
V _{DDA} ⁽¹⁾	Analog operating voltage	1.8	3.6	V
T	Operating temperature	-40	105	°C

(1). V_{DDA} can be lower than V_{DD}. For example, V_{DD} = 3.6 V, V_{DDA} = 3.3 V; V_{DD} = 3.3 V, V_{DDA} = 2.5 V.

4.2.2 PVD characteristics

Table 4-5 PVD characteristics

Symbol	Parameter	Condition	Min	Typ	Max	Unit
V _{PVD}	Programmable voltage detector level selection (V _{DD} rising edge)	PLS[2:0] = 000	2.10	2.23	2.36	V
		PLS[2:0] = 001	2.19	2.33	2.47	
		PLS[2:0] = 010	2.31	2.43	2.55	
		PLS[2:0] = 011	2.40	2.53	2.66	
		PLS[2:0] = 100	2.49	2.63	2.77	
		PLS[2:0] = 101	2.60	2.74	2.88	
		PLS[2:0] = 110	2.68	2.84	3.00	
	Programmable voltage detector level selection (V _{DD} falling edge)	PLS[2:0] = 000	2.11	2.21	2.31	
		PLS[2:0] = 001	2.21	2.31	2.41	
		PLS[2:0] = 010	2.31	2.41	2.51	
		PLS[2:0] = 011	2.40	2.51	2.62	
		PLS[2:0] = 100	2.50	2.61	2.72	
		PLS[2:0] = 101	2.59	2.71	2.83	
		PLS[2:0] = 110	2.69	2.81	2.93	
PLS[2:0] = 111	2.78	2.91	3.04			

4.2.3 POR/PDR characteristics

Table 4-6 POR/PDR characteristics

Symbol	Parameter	Condition	Min	Typ	Max	Unit
V _{POR/PDR} ⁽¹⁾	POR/PDR threshold	Falling edge ⁽²⁾	-	1.70	-	V
		Rising edge	-	1.64	-	V
V _{PDRhyst}	PDR hysteresis	-	-	60	-	mV
t _{RSTTEMPO} ⁽³⁾	Reset duration	-	3.0	3.50	4.50	ms

(1) PDR is based on the monitoring of V_{DD} and V_{DDA}. POR is based on the monitoring of only V_{DD}.

(2) The actual performance value is guaranteed to be smaller than the minimum V_{POR/PDR} value.

(3) The value is guaranteed in design.

4.2.4 Internal reference voltage

Table 4-7 Internal reference voltage characteristics

Symbol	Parameter	Condition	Min	Typ	Max	Unit
V _{REFINT}	Internal reference voltage	-40°C to 105°C	1.15	1.2	1.23	V

4.2.5 Operating current characteristics

Table 4-8 Operating current characteristics

Mode	Condition	Parameter	-40°C, V _{DD} = 3.3 V	25°C, V _{DD} = 3.3 V	85°C, V _{DD} = 3.3 V	105°C, V _{DD} = 3.3 V	Unit
Run	HCLK = 96 MHz, seven wait states for FLASH_LATENCY, APB clock enabled	Operating current	10.636	9.777	10.301	10.743	mA

Mode	Condition	Parameter	-40°C, V _{DD} = 3.3 V	25°C, V _{DD} = 3.3 V	85°C, V _{DD} = 3.3 V	105°C, V _{DD} = 3.3 V	Unit
	HCLK = 96 MHz, seven wait states for FLASH_LATENCY, APB clock disabled		6.933	6.062	6.578	7.008	mA
	HCLK = HSE (8 MHz), zero wait states for FLASH_LATENCY, APB clock enabled		2.857	1.950	2.433	2.844	mA
	HCLK = HSE (8 MHz), zero wait states for FLASH_LATENCY, APB clock disabled		2.543	1.641	2.122	2.533	mA
	HCLK = LSE (32.768 kHz), zero wait states for FLASH_LATENCY, APB clock enabled		0.995	1.080	1.567	1.912	mA
	HCLK = LSE (32.768 kHz), zero wait states for FLASH_LATENCY, APB clock disabled		0.994	1.078	1.565	1.908	mA
	HCLK = LSI (40 kHz), zero wait states for FLASH_LATENCY, APB clock enabled		0.996	1.080	1.517	1.914	mA
	HCLK = LSI (40 kHz), zero wait states for FLASH_LATENCY, APB clock disabled		0.994	1.079	1.514	1.909	mA
Sleep	HCLK = HSE (96 MHz), APB clock disabled	Operating current	5.676	4.786	5.286	5.710	mA
	HCLK = HSI (8 MHz), APB clock disabled	Operating current	1.275	1.363	1.796	2.191	mA
		Wakeup time	-	4.7	-	-	μs
	HCLK = LSE (32.768 kHz), APB clock disabled	Operating current	0.993	1.077	1.561	1.905	mA
HCLK = LSI (40 kHz), APB clock disabled	Operating current	0.993	1.077	1.510	1.905	mA	
Stop	LDO operating at full speed HSE/HSI/LSE disabled IWDG disabled	Operating current	0.628	0.688	1.099	1.487	mA
		Wakeup time	-	20	-	-	μs
	LDO in the low-power state HSE/HSI/LSE disabled IWDG disabled	Operating current	18.227	60.026	393.768	708.269	μA
		Wakeup time	-	132	-	-	μs
Standby	LSI and IWDG enabled	Operating current	1.834	2.254	6.004	10.898	μA
		Wakeup time	-	152	-	-	μs
	LSI enabled, IWDG disabled	Operating current	1.829	2.253	5.993	10.883	μA
		Wakeup time	-	152	-	-	μs
	All oscillators disabled.	Operating current	1.154	1.642	5.393	10.285	μA
		Wakeup time	-	152	-	-	μs
Shutdown	LSE enabled and RTC running (BKPPDS = 0)	Operating current	1.465	2.002	165.692	10.606	μA
		Wakeup time	-	96	-	-	μs
	LSE disabled and RTC stopped (BKPPDS = 0)	Operating current	1.152	1.633	5.306	10.112	μA
		Wakeup time	-	96	-	-	μs

Mode	Condition	Parameter	-40°C, V _{DD} = 3.3 V	25°C, V _{DD} = 3.3 V	85°C, V _{DD} = 3.3 V	105°C, V _{DD} = 3.3 V	Unit
	LSE and RTC disabled (BKPPDS = 1)	Operating current	0.319	0.406	1.027	2.446	μA
		Wakeup time	-	364	-	-	μs

4.2.6 HSE clock characteristics

Table 4-9 HSE clock characteristics

Symbol	Parameter	Condition	Min	Typ	Max	Unit
f _{OSC_IN}	Oscillator frequency	-	4	8	32	MHz
R _F	Feedback resistor	-	-	2	-	MΩ
T _{SU} (HSE)	Oscillator startup time	V _{SS} ≤ V _{IN} ≤ V _{DD}	3	-	4	μs
C	Recommended load capacitance minus equivalent serial resistance of the crystal oscillator (R _s)	-	-	12.5	-	PF
I _{DD} (HSE)	HSE oscillator power consumption	Normal operation: V _{DD} = 3.3 V, C _L = 12.5 pF@8 MHz	60	100	300	μA

HK32ASPIN010xB integrates an HSE negative feedback circuit supplied with a resonator. The following oscillator circuit outside the chip is recommended:

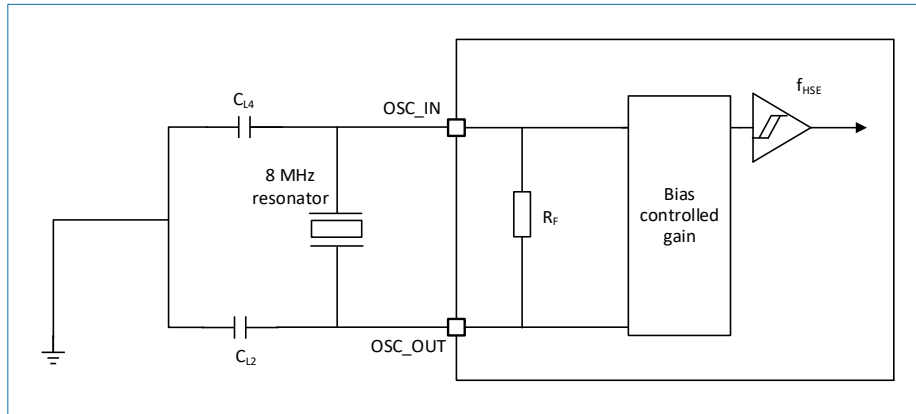

Figure 4-1 HSE crystal oscillator circuit with negative feedback

Alternatively, HK32ASPIN010xB can be clocked from the OSC_IN pin. The following table lists the requirements for this clock signal:

Table 4-10 Characteristics of the input HSE clock

Symbol	Parameter	Condition	Min	Typ	Max	Unit
f _{HSE_ext}	External clock source frequency	-	1	8	25	MHz
V _{HSEH}	High level voltage on the OSC_IN input pin	-	0.7V _{DD}	-	V _{DD}	V
V _{HSEL}	Low level voltage on the OSC_IN input pin	-	V _{SS}	-	0.3V _{DD}	V
t _H (HSE)/t _L (HSE)	High or low time of OSC_IN	-	5	-	-	ns
t _r (HSE)/t _f (HSE)	Rise or fall time of OSC_IN	-	-	-	20	ns
C _{in} (HSE)	OSC_IN input capacitance	-	-	5	-	pF
DuCY _(HSE)	Duty cycle	-	45	-	55	%

4.2.7 LSE clock characteristics

 Table 4-11 LSE clock characteristics (f_{LSE} = 32.768 kHz)

Symbol	Parameter	Condition	Min	Typ	Max	Unit
R _F	Feedback resistor	-	-	2	-	MΩ
T _{SU} (LSE)	Oscillator startup time	V _{SS} ≤ V _{IN} ≤ V _{DD}	-	-	2000	ms
C	Recommended load capacitance minus	-	-	12.5	-	pF

Symbol	Parameter	Condition	Min	Typ	Max	Unit
	equivalent serial resistance of the crystal oscillator					
I_2	LSE driving current	-	-	400	-	nA
$I_{DD(LSE)}$	LSE oscillator power consumption	Normal operation: $V_{DD} = 3.3\text{ V}$, $CL = 12.5\text{ pF}@8\text{ MHz}$	-	80	100	μA

HK32ASPIN010xB integrates an LSE negative feedback circuit supplied with a resonator. The following oscillator circuit outside the chip is recommended:

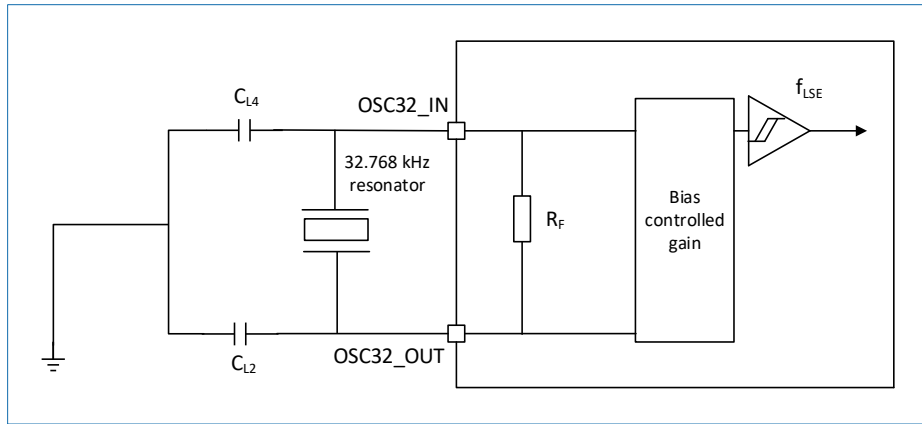

Figure 4-2 LSE crystal oscillator circuit with negative feedback

Alternatively, HK32ASPIN010xB can be clocked from the OSC32_IN pin. The following table lists the requirements for this clock signal.

Table 4-12 Characteristics of the input LSE clock

Symbol	Parameter	Condition	Min	Typ	Max	Unit
f_{LSE_ext}	External clock source frequency	-	-	32.768	1000	kHz
V_{LSEH}	High level voltage on the OSC_IN input pin	-	$0.7V_{DD}$	-	V_{DD}	V
V_{LSEL}	Low level voltage on the OSC_IN input pin	-	V_{SS}	-	$0.3V_{DD}$	V
$t_{H(LSE)}/t_{L(LSE)}$	High or low time of OSC_IN	-	450	-	-	ns
$t_{r(LSE)}/t_{f(LSE)}$	Rise or fall time of OSC_IN	-	-	-	50	ns
$C_{in(LSE)}$	OSC_IN input capacitance	-	-	5	-	pF
$DuCy_{(LSE)}$	Duty cycle	-	30	-	70	%

4.2.8 HSI clock characteristics

Table 4-13 HSI clock characteristics

Symbol	Parameter	Condition	Min	Typ	Max	Unit	
f_{HSI}	Frequency	-	-	8	-	MHz	
$DuCy_{(HSI)}$	Duty cycle	-	45	-	55	%	
$ACC_{(HSI)}$	Oscillator accuracy	RCC_CR register calibration completed by the user	-	-	1	%	
		Factory calibrated	$T_A = -40^\circ\text{C}$ to $+105^\circ\text{C}$	-1.5	-		1.5
			$T_A = -40^\circ\text{C}$ to $+85^\circ\text{C}$	-1.0	-		1.0
			$T_A = 0^\circ\text{C}$ to $+70^\circ\text{C}$	-1.0	-		1.0
$T_{su(HSI)}$	Oscillator startup time	$V_{SS} \leq V_{IN} \leq V_{DD}$	3	-	4	μs	
$I_{DD(HSI)}$	Oscillator power consumption	-	-	80	100	μA	

4.2.9 LSI clock characteristics

Table 4-14 LSI clock characteristics

Symbol	Parameter	Condition	Min	Typ	Max	Unit
f_{LSI}	Frequency	-	34	40	46	kHz
$T_{SU(LSI)}$	Oscillator startup time	$V_{SS} \leq V_{IN} \leq V_{DD}$	-	150	-	μs
$I_{DD(LSI)}$	Oscillator power consumption	-	-	0.5	-	μA

4.2.10 PLL characteristics

Table 4-15 PLL characteristics

Symbol	Parameter	Min	Typ	Max	Unit
f_{PLL_IN}	Input clock frequency	2	8.0	80	MHz
	Input clock duty cycle	40	-	60	%
f_{PLL_OUT}	Output clock frequency	16	-	120	MHz
t_{LOCK}	PLL lock time	-	80	120	μs
Jitter	Cycle-to-cycle jitter	-	5	13	ps

4.2.11 Flash memory characteristics

Table 4-16 Flash memory characteristics

Symbol	Parameter	Min	Typ ⁽¹⁾	Max	Unit
T_{PROG}	Half word programming time	-	42	-	μs
	One-word programming time	-	42	-	μs
T_{ERASE}	Half page erase time	-	3.7	-	ms
	Page erase time	-	7.45	-	ms
	Mass erase time	-	190	-	ms
I_{DDPROG}	Programming current	-	1.5	5	mA
$I_{DDERASE}$	Page/Mass erase current	-	0.9	2	mA
I_{DDREAD}	Supply current@24 MHz (read mode)	-	2.5	-	mA
N_{END}	Erasures endurance	100,000	-	-	Cycles
t_{RET}	Data retention	10	-	-	Years

(1). The typical values are obtained in the following conditions: 1.5 V, TT process corner, 25°C.

4.2.12 I/O pin input characteristics

Table 4-17 I/O pin input direct current characteristics

Symbol	Parameter	Condition	Min	Typ	Max	Unit
V_{IH}	Input high level voltage	$V_{DD} = 3.3 V$	1.82	-	-	V
V_{IL}	Input low level voltage	$V_{DD} = 3.3 V$	-	-	1.3	V
V_{IHhys}	Input high level voltage	$V_{DD} = 3.3 V$	1.64	-	-	V
V_{ILhys}	Input low level voltage	$V_{DD} = 3.3 V$	-	-	1.44	V
V_{hys}	Schmitt trigger voltage hysteresis	$V_{DD} = 3.3 V$	-	160	-	mV
I_{Ikg}	Input leakage current	$V_{DD} = 3.3 V; 0 < V_{IN} < 3.3 V$	-	-	0.01	μA
		$V_{DD} = 3.3 V; V_{IN} = 5 V$	-	-	1.65	μA
R_{PU}	Pull-up resistor	$V_{IN} = V_{SS}$	-	33	-	k Ω
R_{PD}	Pull-down resistor	$V_{IN} = V_{DD}$	-	34	-	k Ω
C_{IO}	I/O pin capacitance	-	-	5	-	pF

4.2.13 I/O pin output characteristics

Table 4-18 I/O pin output alternating current characteristics

Mode	Symbol	Parameter	Condition	Min	Typ	Max	Unit
OSPEEDY[1:0]							
x0	$t_{f(I)out}$	Output high to low level fall time	CL = 50 pF, $V_{DD} = 3.3 V$	-	9.50	-	ns
	$t_{r(I)out}$	Output low to high level rise time		-	22.7	-	ns
01	$t_{f(I)out}$	Output high to low level fall time	CL = 50 pF, $V_{DD} = 3.3 V$	-	5.0	-	ns

Mode	Symbol	Parameter	Condition	Min	Typ	Max	Unit
OSPEEDy[1:0]	$t_{r(I)out}$	Output low to high level rise time		-	6.70	-	ns
11	$t_{r(I)out}$	Output high to low level fall time	CL = 50 pF, V _{DD} = 3.3 V	-	4.25	-	ns
	$t_{r(I)out}$	Output low to high level rise time		-	5.00	-	ns
OSPEEDy[1:0] = 11 and UHDy = 1	$t_{r(I)out}$	Output high to low level fall time	CL = 50 pF, V _{DD} = 3.3 V	-	3.35	-	ns
	$t_{r(I)out}$	Output low to high level rise time		-	3.85	-	ns

4.2.14 NRST pin characteristics

The NRST pin is connected to a pull-up resistor. Its peripheral application circuit can connect to an external RC circuit or no circuit.

Table 4-19 NRST pin input characteristics

Symbol	Parameter	Min	Max	Unit
T _{Noise}	Low level ignored duration	-	50	ns

4.2.15 TIM timer characteristics

Table 4-20 TIM pin input characteristics

Symbol	Condition	Min	Max	Unit
F _{EXT}	Timer external clock frequency on CH1 to CH4	0	F _{TIMxCLK} /2 ⁽¹⁾	MHz

(1). f_{TIMxCLK} = 96 MHz

4.2.16 EMACC characteristics

Table 4-21 Motor drive frequency characteristics

System Clock	ADC Clock	Min	Typ	Max	Unit
48 MHz	f _{PCLK} = f _{apb} f _{ADC} = f _{PCLK} /4	-	20	21±0.3	kHz
72 MHz	f _{PCLK} = f _{apb} f _{ADC} = f _{PCLK} /4	-	24	25±0.3	kHz
96 MHz	f _{PCLK} = f _{apb} /2 f _{ADC} = f _{PCLK} /4	-	28	29±0.3	kHz

Table 4-22 Comparison between the software and the FOC algorithm with EMACC

Test Condition	Electrical Angle	Coordinate System Conversion	Software-based SVPWM	Total Time Consumption	Unit
System clock: 48 MHz (software-based motor library)	12	13	7	32	μs
System clock: 48 MHz (EMACC-powered motor library)	12	2.8	7	21.8	μs

4.2.17 ADC characteristics

Table 4-23 ADC characteristics

Item	Description	Condition	Min	Typ	Max	Unit
V _{DDA}	Analog power supply voltage when ADC is enabled	-	2.4	-	3.6	V
INL	Integral non linearity (maximum difference between the actual conversion point and the end point correlation line)	f _{ADC} = 14 MHz R _{AIN} < 10 kΩ Test after calibration V _{DDA} = 2.4 V to 3.6 V	-	±1	-2 to 3	LSB
DNL	Differential non linearity (maximum difference between the actual step and the ideal step)	f _{ADC} = 14 MHz R _{AIN} < 10 kΩ Test after calibration V _{DDA} = 2.4 V to 3.6 V	-	±1	-2 to 3	LSB
f _{ADC}	ADC clock frequency	-	0.6	-	14	MHz

Item	Description	Condition	Min	Typ	Max	Unit
$f_s^{(1)}$	Sampling frequency	-	0.05		1	MHz
$f_{TRIG}^{(1)}$	External trigger frequency	$f_{ADC} = 14$ MHz	-	-	823	kHz
		-	-	-	17	1/ f_{ADC}
V_{AIN}	Conversion voltage range	-	0	-	V_{DDA}	V
$R_{AIN}^{(1)}$	External input impedance	For details, see Table 4-24.	-	-	60	k Ω
$R_{ADC}^{(1)}$	Sampling switch resistance	-	-	-	1	k Ω
$C_{ADC}^{(1)}$	Sampling and hold capacitor	-	-	-	5	pF
$t_{CAL}^{(2)}$	ADC calibration time	$f_{ADC} = 14$ MHz	5.9			μ s
		-	8.3			1/ f_{ADC}
t_{latr}	Trigger conversion latency	$f_{ADC} = f_{PCLK}/2 = 14$ MHz	0.196			μ s
		$f_{ADC} = f_{PCLK}/2$	5.5			1/ f_{PCLK}
		$f_{ADC} = f_{PCLK}/4 = 12$ MHz	0.219			μ s
		$f_{ADC} = f_{PCLK}/4$	10.5			1/ f_{PCLK}
		$f_{ADC} = f_{HSI14} = 14$ MHz	0.188	-	0.259	μ s
Jitter $_{ADC}$	Jitters triggered by ADC conversions	$f_{ADC} = f_{HSI14}$	-	1	-	1/ f_{HSI14}
$t_s^{(1)}$	Sampling time	$f_{ADC} = 14$ MHz	0.107		17.1	μ s
		-	1.5		239.5	1/ f_{ADC}
$t_{STAB}^{(1)}$	Sampling stable time	-	14			μ s
$t_{CONV}^{(1)}$	Total conversion time (including sampling time)	$f_{ADC} = 14$ MHz	1	-	18	μ s
		12-bit resolution	14 to 252 ($t_{CONV} =$ sampling time t_s + conversion time 12.5)			1/ f_{ADC}

(1). The value is guaranteed in design but not tested in production.

(2). The value is measured based on the ADC clock. The register access latency is not taken into account.

The calculation formula of the maximum input impedance R_{AIN} :

$$R_{AIN} < \frac{Ts}{f_{ADC} \times C_{ADC} \times \ln(2^{N+2})} - R_{ADC}$$

The value of N (resolution) is 12.

The allowable error can be lower than 1/4 least significant bit (LSB).

Table 4-24 Maximum input impedance values ($f_{adc} = 14$ MHz)

Sampling Cycles (Cycles)	Sampling Time t_s (μ s)	Maximum Input Impedance (k Ω)
1.5	0.11	1.21
7.5	0.54	10.05
13.5	0.96	18.88
28.5	2.04	40.97
41.5	2.96	60.12
55.5	3.96	80.74
71.5	5.11	N/A
239.5	17.1	N/A

Table 4-25 ADC accuracy

Symbol	Parameter	Test Condition	Typ	Max	Unit
ET	Total unadjusted error ⁽¹⁾	SystemCLK = 56 MHz	-1 to 1	-2 to 3	LSB
EO	Offset error ⁽²⁾	ADCCLK = 14 MHz	1	0 to 2	
EG	Gain error ⁽³⁾	Input impedance < 10 k Ω	3	1 to 3	
ED	Differential linearity error ⁽⁴⁾	$V_{DD} = V_{DDA} = 3.305$ V	-1 to 1	-2 to 3	
EL	Integral linearity error ⁽⁵⁾	Test after ADC calibration	-1 to 1	-2 to 3	

(1). Total unadjusted error: The maximum deviation between the actual transfer curve and the ideal transfer curve.

(2). Offset error: The deviation between the first actual conversion and the first ideal conversion.

(3). Gain error: The deviation between the last ideal conversion and the last actual conversion.

(4). Differential linearity error: The maximum deviation between the actual step and the ideal step.

(5). Integral linearity error: The maximum deviation between any actual transition and the endpoint correlation line.

Note:

- The ADC direct current accuracy values are measured after internal calibration.
- ADC accuracy and negative current injection: Avoid injecting negative currents on any standard (non-robust) analog input pin. Otherwise, the accuracy of the conversion being performed on another analog input pin is greatly reduced. It is recommended that you add a Schottky diode (pin to ground) to the standard analog pins on which negative currents may be injected.
- With restricted V_{DDA} , frequency, and temperature ranges, better ADC performance can be achieved.
- The data is based on characterization but not tested in production.

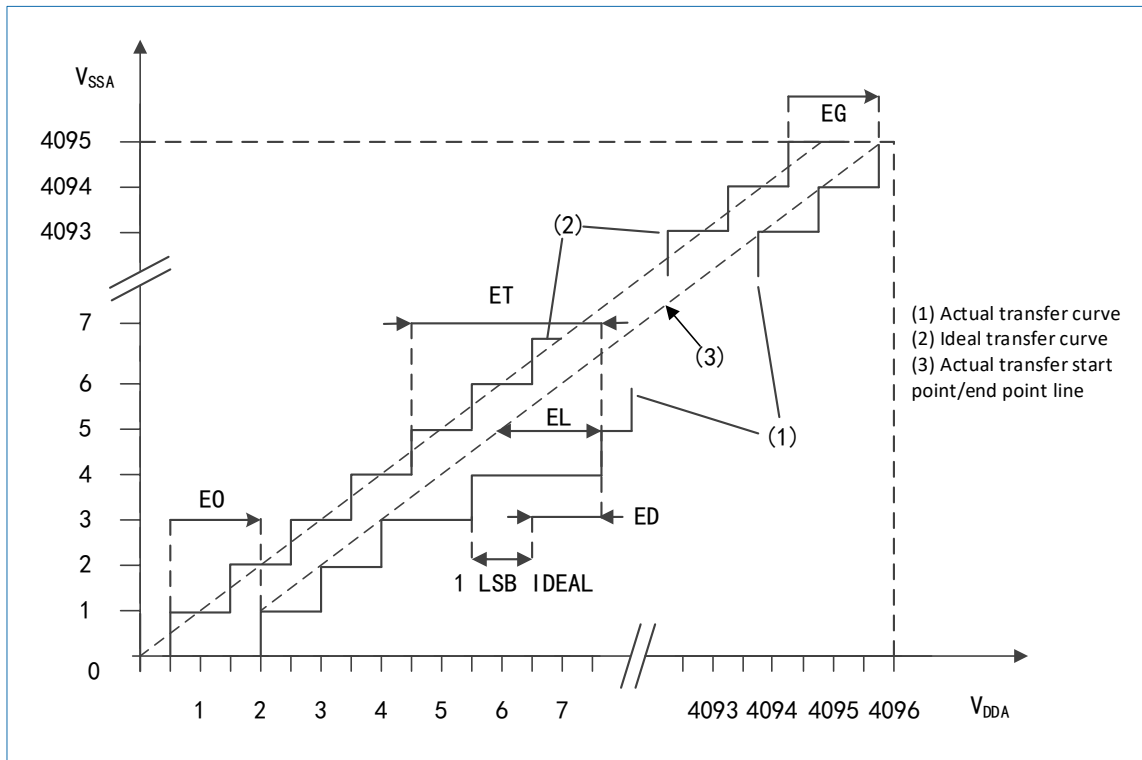

Figure 4-3 ADC accuracy characteristics

Note: For the explanations of EO, ET, EG, EL, and ED, see [Table 4-25](#).

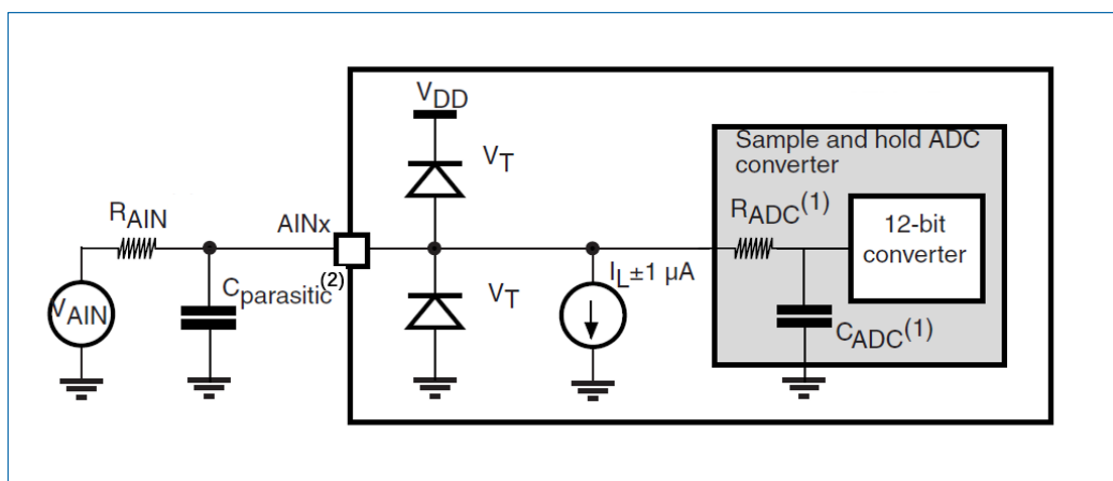

Figure 4-4 Typical connection diagram of ADC

- (1). For the ADC characteristics of R_{ADC} and C_{ADC} , see [Table 4-23](#).
- (2). $C_{parasitic}$ equals the PCB capacitance (decided by soldering and the PCB layout quality) plus the pad capacitance (about 7 pF). A high $C_{parasitic}$ value would reduce conversion accuracy, so f_{ADC} should be reduced.

PCB design recommendation for ADC sampling: The power supply decoupling should be performed by following

section "5 Typical circuitry". To ensure the ADC conversion accuracy, the 10 nF capacitors should be ceramic and placed close to the chip.

4.2.18 Temperature sensor characteristics

Table 4-26 Temperature sensor characteristics

Symbol	Parameter	Condition	Min	Typ	Max	Unit
T _L	Temperature sensor linearity error	-	-	±1	±3	°C
V ₂₅	Output voltage	25°C	0.85	0.89	0.93	V
Avg_Slope	Temperature sensor slope	-	-	3	-	mV/°C

5 Typical circuitry

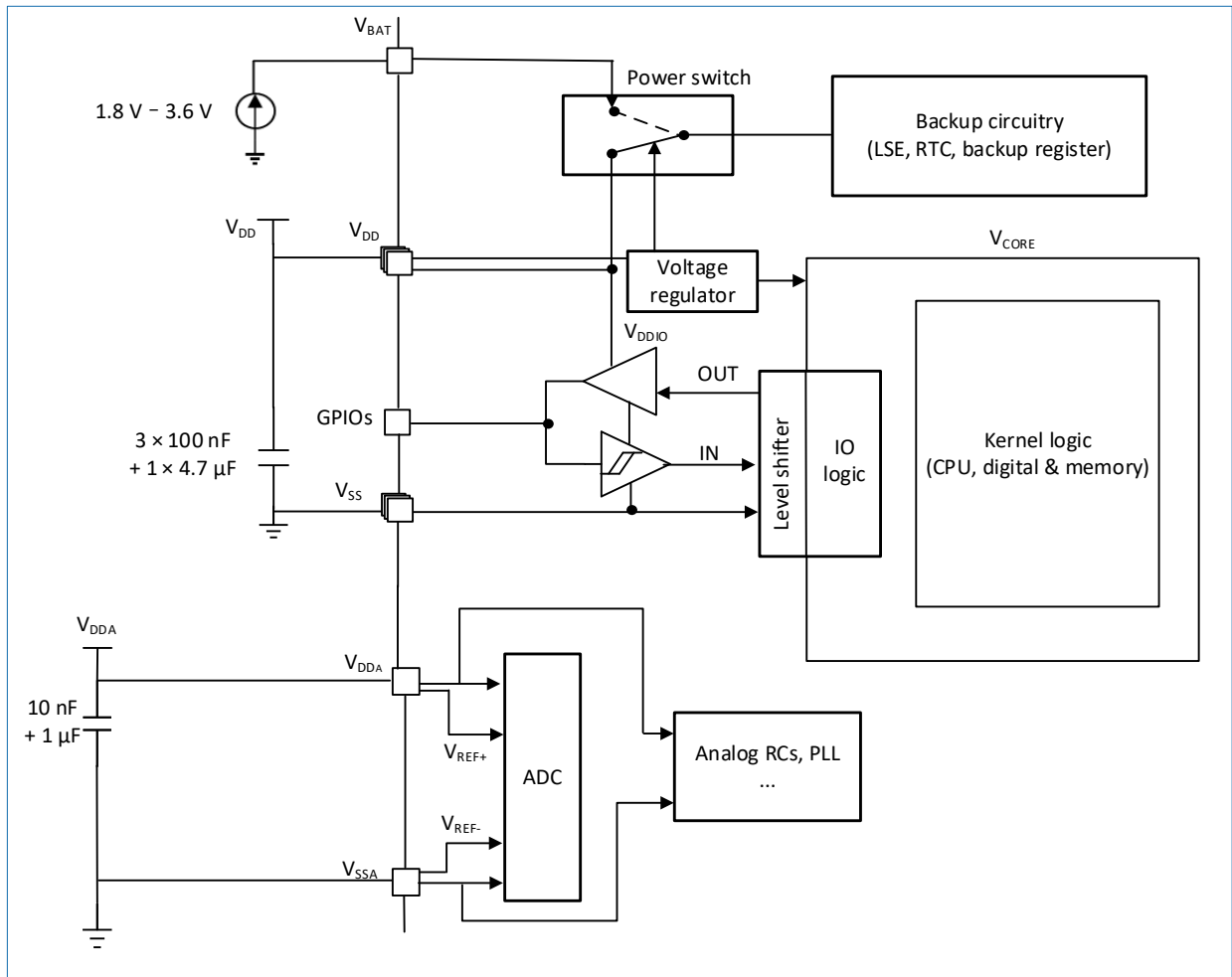

Figure 5-1 Power supply reference circuitry

6 Pinouts and pin descriptions

HK32ASPIN010xB MCUs are delivered in TSSOP20, QFN28, QFN32, LQFP32, LQFP48, and LQFP64 packages. The pinouts of the packages are as follows:

6.1 TSSOP20

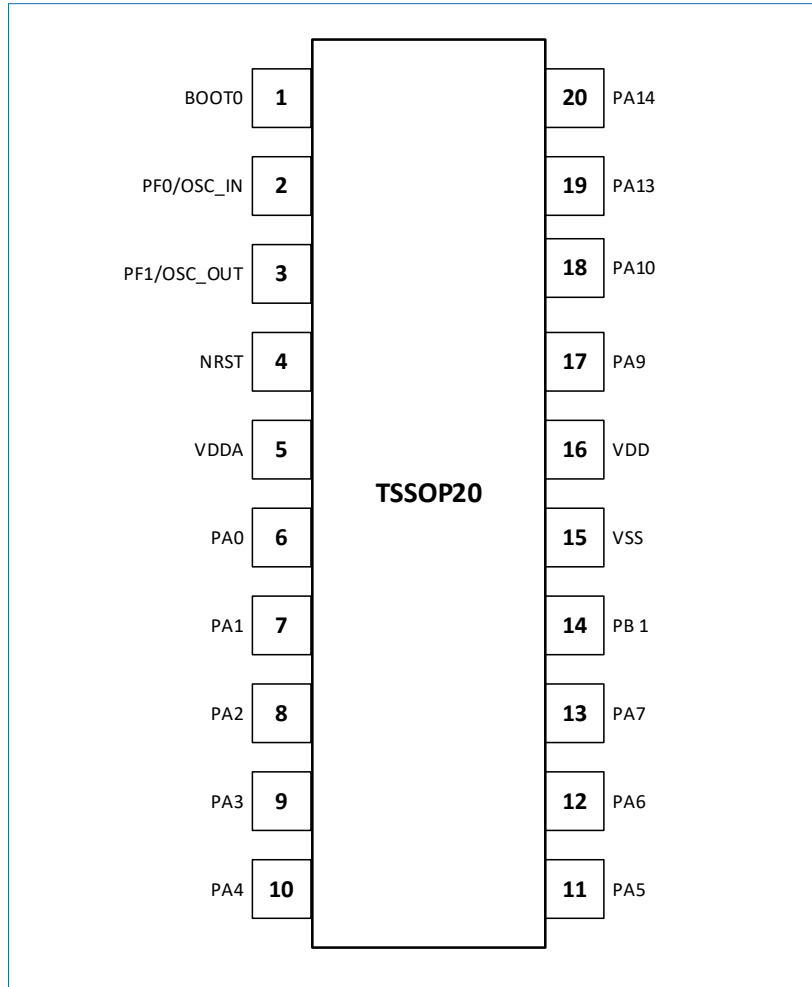

Figure 6-1 TSSOP20 pinout

6.2 QFN28

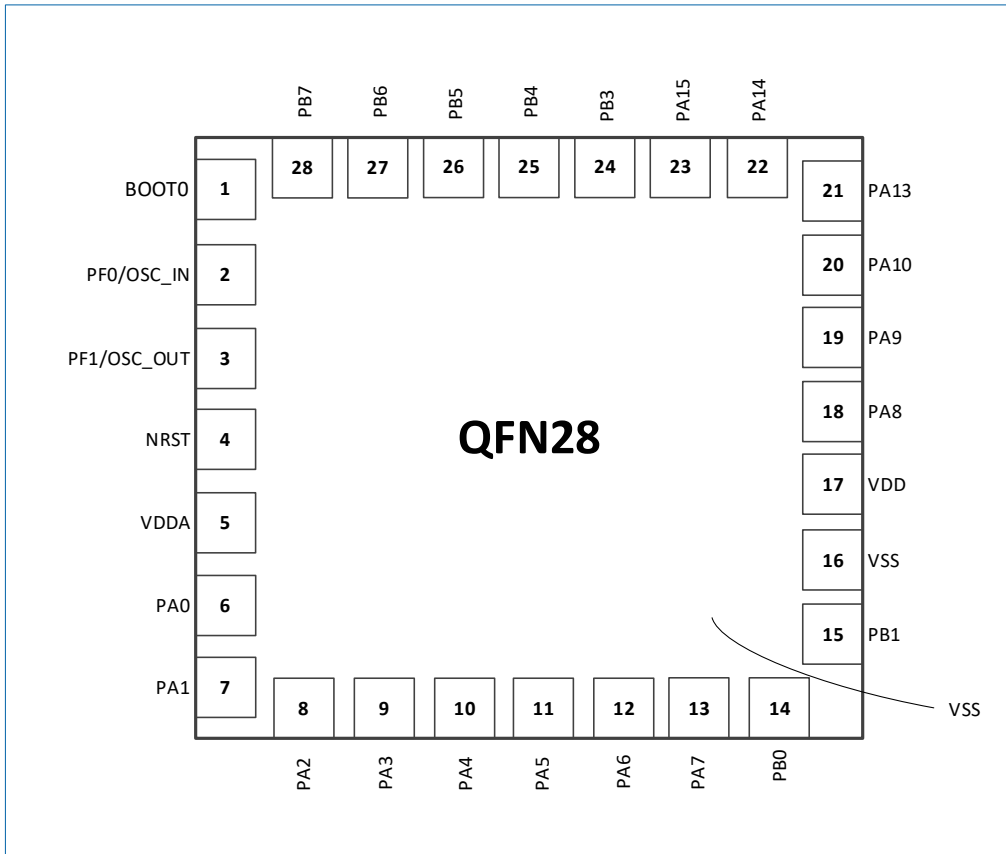

Figure 6-2 QFN28 pinout

6.3 QFN32

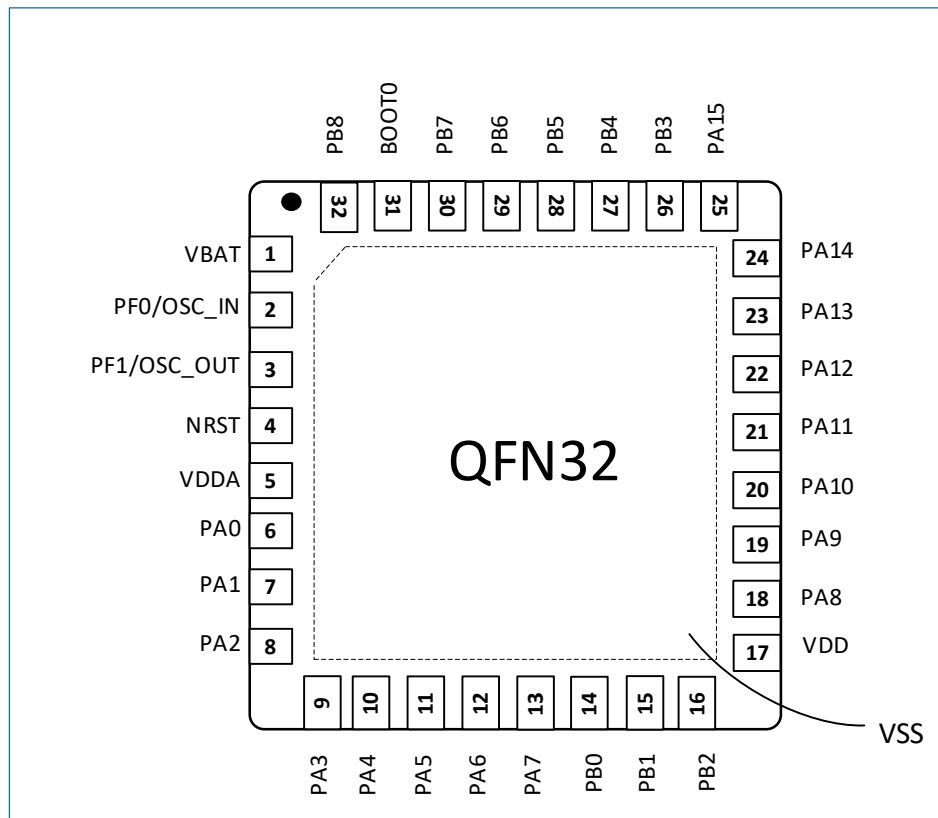

Figure 6-3 QFN32 pinout

6.4 LQFP32

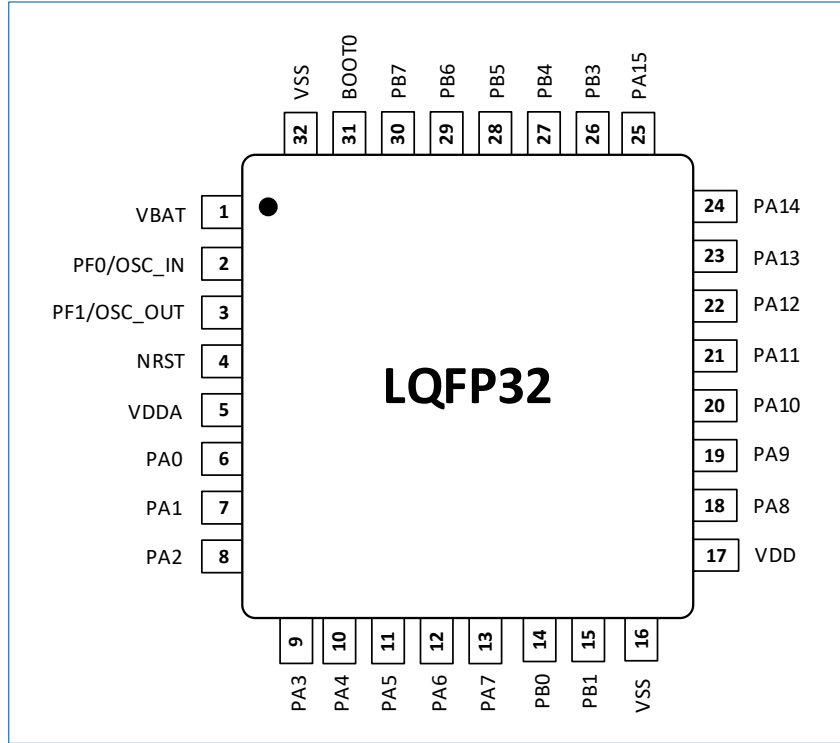

Figure 6-4 LQFP32 pinout

6.5 LQFP48

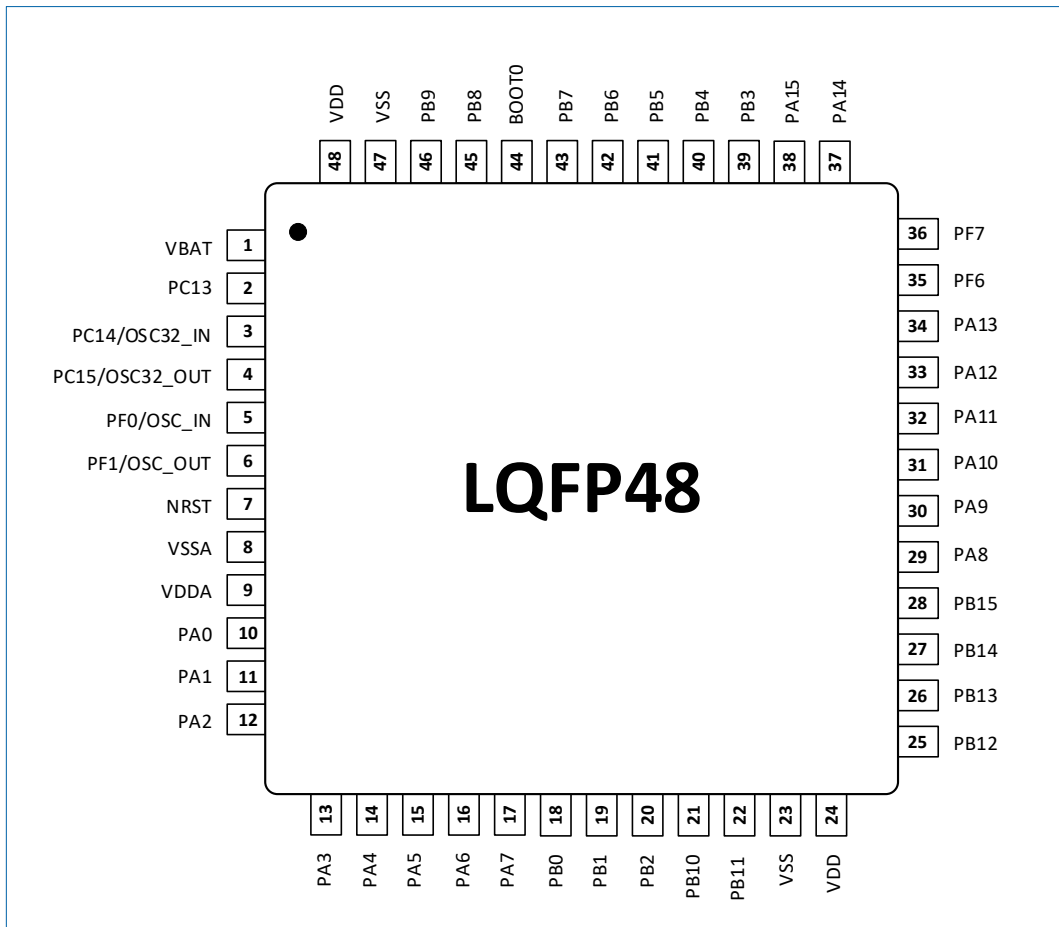

Figure 6-5 LQFP48 pinout

6.6 LQFP64

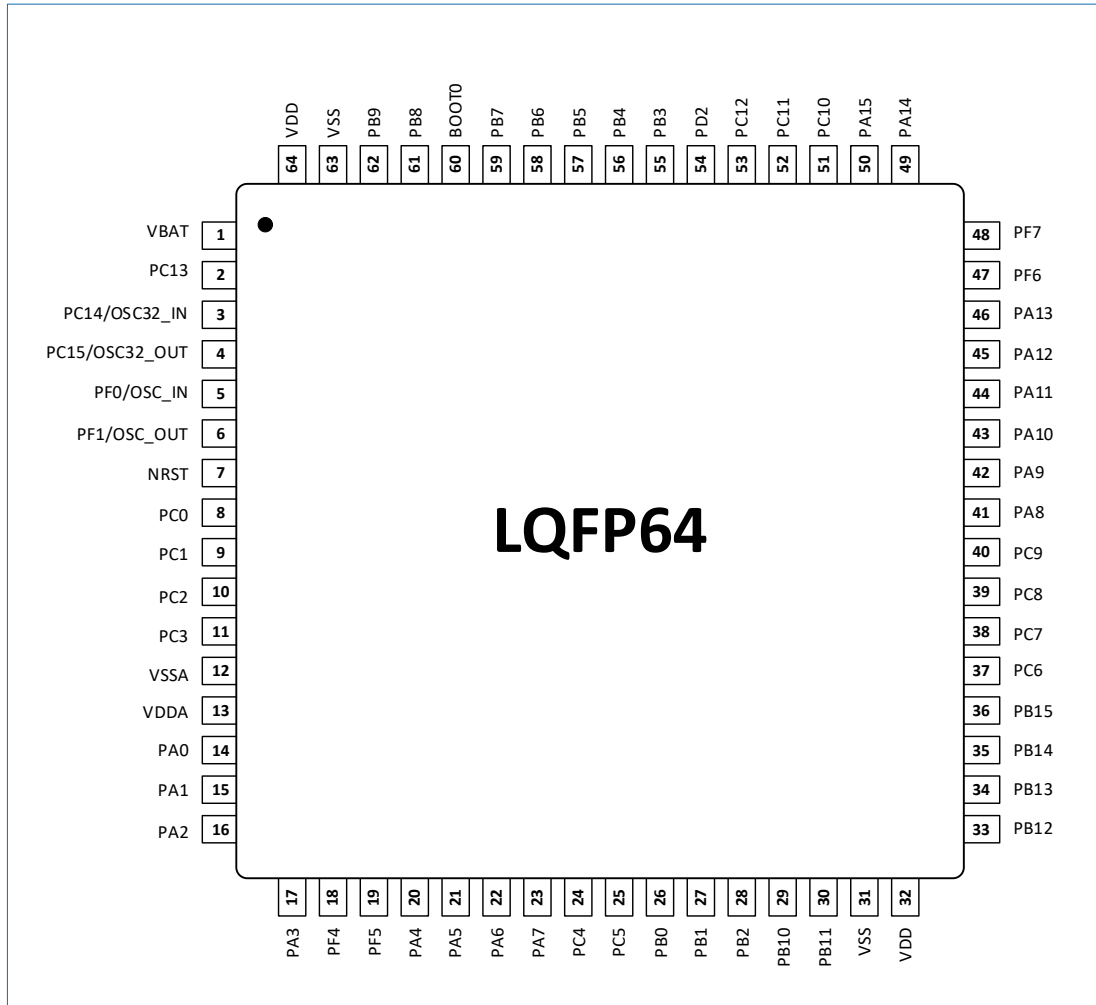

Figure 6-6 LQFP64 pinout

6.7 Pin descriptions

Table 6-1 Pin description of each package

TSSOP20	QFN28	QFN32	LQFP32	LQFP48	LQFP64	Pin Name	Pin Type ⁽¹⁾	5 V-tolerant	Alternate Function	Additional Function
-	-	-	-	1	1	VBAT	S		Battery power supply input	
-	-	-	-	2	2	PC13	I/O	FT	-	RTC_TAMP1 RTC_TS RTC_OUT WKUP2 EXTI13
-	-	-	-	3	3	PC14	I/O	FT	-	OSC32_IN EXTI14
-	-	-	-	4	4	PC15	I/O	FT	-	OSC32_OUT EXTI15
2	2	2	2	5	5	PF0	I/O	FT	I2C1_SDA	OSC_IN
3	3	3	3	6	6	PF1	I/O	FT	I2C1_SCL	OSC_OUT
4	4	4	4	7	7	NRST	I/O	-	Reset input/internal reset output, active low	
-	-	-	-	-	8	PC0	I/O	-	LPTIM_IN1	ADC_IN10 EXTI0
-	-	-	-	-	9	PC1	I/O	-	LPTIM_OUT	ADC_IN11 EXTI1
-	-	-	-	-	10	PC2	I/O	-	SPI2_MISO I2S2_MCK LPTIM_IN2	ADC_IN12 EXTI2

TSSOP20	QFN28	QFN32	LQFP32	LQFP48	LQFP64	Pin Name	Pin Type ⁽¹⁾	5 V-tolerant	Alternate Function	Additional Function
-	-	-	-	-	11	PC3	I/O	-	SPI2_MOSI I2S2_SD LPTIM_ETR	ADC_IN13 EXTI3
-	-	-	-	8	12	VSSA	S	-	Analog ground	
5	5	5	5	9	13	VDDA	S	-	Analog power supply	
6	6	6	6	10	14	PA0	I/O	-	USART1_CTS USART2_CTS TIM2_CH1 TIM2_ETR CMP1_ININ1/CMP1_OUT LPUART_RX LPTIM_IN1 CLU0_O CLU1_O CLU2_O CLU3_O	ADC_IN0 WKUP1 RTC_TAMP2 EXTCLK4 EXTI0
7	7	7	7	11	15	PA1	I/O	-	USART1_RTS/USART1_DE USART2_RTS/USART2_DE TIM15_CH1N TIM2_CH2 CMP1_INP1 LPTIM_IN2 CLU0_O CLU1_O CLU2_O CLU3_O	ADC_IN1 EXTI1
8	8	8	8	12	16	PA2	I/O	-	USART1_TX USART2_TX TIM15_CH1 TIM2_CH3 CMP2_INN1 CMP2_OUT LPTIM_ETR CLU0_O CLU1_O CLU2_O CLU3_O	ADC_IN2 EXTI2
9	9	9	9	13	17	PA3	I/O	-	USART1_RX USART2_RX TIM15_CH2 TIM2_CH4 CMP2_INP1 LPTIM_OUT CLU0_O CLU1_O CLU2_O CLU3_O	ADC_IN3 EXTI3
-	-	-	-	-	18	PF4	I/O	-	-	ADC_AIN17 EXTI4
-	-	-	-	-	19	PF5	I/O	FT	-	EXTI5
10	10	10	10	14	20	PA4	I/O	-	SPI1_NSS I2S1_WS USART1_CK USART2_CK TIM14_CH1 CMP1_INN2 CMP2_INN2 CMP3_INN2 CLU0_O CLU1_O CLU2_O CLU3_O	ADC_IN4 EXTCLK1 EXTI4

TSSOP20	QFN28	QFN32	LQFP32	LQFP48	LQFP64	Pin Name	Pin Type ⁽¹⁾	5 V-tolerant	Alternate Function	Additional Function
									DAC1_AOUT0	
11	11	11	11	15	21	PA5	I/O	-	SPI1_SCK I2S1_CK TIM2_CH1 TIM2_ETR CMP1_INN3 CMP2_INN3 CMP3_INN1 CLU0_O CLU1_O CLU2_O CLU3_O	ADC_IN5 EXTI5
12	12	12	12	16	22	PA6	I/O	-	SPI1_MISO I2S1_MCK TIM3_CH1 TIM1_BKIN TIM16_CH1 CMP1_OUT LPUART_CTS CAN_RX CLU0_O CLU1_O CLU2_O CLU3_O	ADC_IN6 EXTI6
13	13	13	13	17	23	PA7	I/O	-	SPI1_MOSI I2S1_SD TIM3_CH2 TIM14_CH1 TIM1_CH1N TIM17_CH1 RCC_MCO CMP2_OUT CAN_TX CLU0_O CLU1_O CLU2_O CLU3_O	ADC_IN7 EXTI7
-	-	-	-	-	24	PC4	I/O	-	LPUART_TX	ADC_IN14 EXTI4
-	-	-	-	-	25	PC5	I/O	-	LPUART_RX	ADC_IN15 EXTI5
-	14	14	14	18	26	PB0	I/O	-	TIM3_CH3 TIM1_CH2N CMP3_INN3	ADC_IN8 EXTI0
14	15	15	15	19	27	PB1	I/O		TIM3_CH4 TIM14_CH1 TIM1_CH3N CMP3_INN1/CMP3_OUT LPUART_RTS/LPUART_DE CLU0_O CLU1_O CLU2_O CLU3_O	ADC_IN9 EXTI1
-	-	16	-	20	28	PB2	I/O	FT	I2C1_SMBA I2C2_SMBA LPTIM_OUT	EXTI2
-	-	-	-	21	29	PB10	I/O	FT	I2C1_SCL I2C2_SCL SPI2_SCK I2S2_CK TIM2_CH3 LPUART_TX	EXTI10

TSSOP20	QFN28	QFN32	LQFP32	LQFP48	LQFP64	Pin Name	Pin Type ⁽¹⁾	5 V-tolerant	Alternate Function	Additional Function
-	-	-	-	22	30	PB11	I/O	FT	I2C1_SDA I2C2_SDA TIM2_CH4 LPUART_RX	EXTI11
15	16	-	16	23	31	VSS	I/O	-	Ground	
16	17	17	17	24	32	VDD	I/O	-	Digital power supply	
-	-	-	-	25	33	PB12	I/O	FT	SPI1_NSS I2S1_WS SPI2_NSS I2S2_WS TIM1_BKIN TIM15_BKIN I2C2_SMBA LPUART_RTS/LPUART_DE	EXTI12
-	-	-	-	26	34	PB13	I/O	FT	SPI1_SCK I2S1_CK SPI2_SCK I2S2_CK TIM1_CH1N I2C2_SCL LPUART_CTS	EXTI13
-	-	-	-	27	35	PB14	I/O	FT	SPI1_MISO I2S1_MCK SPI2_MISO I2S2_MCK TIM1_CH2N TIM15_CH1 I2C2_SDA LPUART_RTS/LPUART_DE	EXTI14
-	-	-	-	28	36	PB15	I/O	FT	SPI1_MOSI I2S1_SD SPI2_MOSI I2S2_SD TIM1_CH3N TIM15_CH1N TIM15_CH2	EXTI15 RTC_REFIN
-	-	-	-	-	37	PC6	I/O	FT	TIM3_CH1 LPTIM_IN1	EXTI6
-	-	-	-	-	38	PC7	I/O	FT	TIM3_CH2 LPTIM_OUT	EXTI7
-	-	-	-	-	39	PC8	I/O	FT	TIM3_CH3 LPTIM_IN2	EXTI8
-	-	-	-	-	40	PC9	I/O	FT	TIM3_CH4 LPTIM_ETR	EXTI9
-	18	18	18	29	41	PA8	I/O	FT	USART1_CK TIM1_CH1 RCC_MCO LPUART_RX	WKUP3 EXTI8
17	19	19	19	30	42	PA9	I/O	FT	USART1_TX TIM1_CH2 TIM15_BKIN I2C1_SCL RCC_MCO LPUART_TX CAN_RX	EXTI9
18	20	20	20	31	43	PA10	I/O	FT	USART1_RX TIM1_CH3 TIM17_BKIN I2C1_SDA LPUART_RX CAN_TX	EXTI10
-	-	21	21	32	44	PA11	I/O	-	USART1_CTS	EXTI11

TSSOP20	QFN28	QFN32	LQFP32	LQFP48	LQFP64	Pin Name	Pin Type ⁽¹⁾	5 V-tolerant	Alternate Function	Additional Function
									TIM1_CH4 I2C2_SCL CAN_RX CMP1_OUT CLU0_O CLU1_O CLU2_O CLU3_O	
-	-	22	22	33	45	PA12	I/O	-	USART1_RTS/USART1_DE TIM1_ETR I2C2_SDA CAN_TX CMP2_OUT CLU0_O CLU1_O CLU2_O CLU3_O	EXTI12
19	21	23	23	34	46	PA13	I/O	FT	IRTIM_IROUT SWDIO CAN_RX LPUART_RX CMP3_OUT CLU0_O CLU1_O CLU2_O CLU3_O	EXTCLK2 EXTI13
-	-	-	-	35	47	PF6	I/O	FT	I2C1_SCL I2C2_SCL	EXTI6
-	-	-	-	36	48	PF7	I/O	FT	I2C1_SDA I2C2_SDA	EXTI7
20	22	24	24	37	49	PA14	I/O	FT	USART1_TX USART2_TX SWCLK CAN_TX LPUART_TX CLU0_O CLU1_O CLU2_O CLU3_O	EXTCLK3 EXTI14
-	23	25	25	38	50	PA15	I/O	FT	SPI1_NSS I2S1_WS USART1_RX USART2_RX TIM2_CH1 TIM2_ETR	EXTI15
-	-	-	-	-	51	PC10	I/O	FT	LPUAR_TX LPTIM_IN1 CLU0_O CLU1_O CLU2_O CLU3_O	EXTI10
-	-	-	-	-	52	PC11	I/O	FT	CAN_RX LPUART_RX LPTIM_OUT CLU0_O CLU1_O CLU2_O CLU3_O	EXTI11
-	-	-	-	-	53	PC12	I/O	FT	CAN_TX LPTIM_IN2 CLU0_O CLU1_O	EXTI12

TSSOP20	QFN28	QFN32	LQFP32	LQFP48	LQFP64	Pin Name	Pin Type ⁽¹⁾	5 V-tolerant	Alternate Function	Additional Function
									CLU2_O CLU3_O	
-	-	-	-	-	54	PD2	I/O	FT	TIM3_ETR LPUART_DE/LPUART_RTS LPTIM_ETR	EXTI2
-	24	26	26	39	55	PB3	I/O	FT	SPI1_SCK I2S1_CK TIM2_CH2 CMP3_OUT	EXTI3
-	25	27	27	40	56	PB4	I/O	FT	SPI1_MISO I2S1_MCK TIM3_CH1 TIM17_BKIN	EXTI4
-	26	28	28	41	57	PB5	I/O	FT	SPI1_MOSI I2S1_SD I2C1_SMBA TIM16_BKIN TIM3_CH2 LPTIM_IN1	EXTI5
-	27	29	29	42	58	PB6	I/O	FT	I2C1_SCL USART1_TX TIM16_CH1N LPUART_TX LPTIM_ETR	EXTI6
-	28	30	30	43	59	PB7	I/O	FT	I2C1_SDA USART1_RX TIM17_CH1N LPUART_RX LPTIM_IN2	EXTI7
1	1	31	31	44	60	Boot0 ⁽²⁾	I		Boot mode configuration	
-	-	32	-	45	61	PB8	I/O	FT	I2C1_SCL TIM16_CH1 CAN_RX	EXTI8
-	-	-	-	46	62	PB9	I/O	FT	I2C1_SDA IRTIM_IROUT TIM17_CH1 SPI2_NSS I2S2_WS CAN_TX	EXTI9
-	0 ⁽³⁾	0 ⁽³⁾	32	47	63	VSS	S		Ground	
-	-	1	1	48	64	VDD	S		Digital power supply	

(1). I = input, O = output, I/O = input/output, S = power supply.

(2). By default, the Boot0 pin has a 50 kΩ pull-down resistor.

(3). In the QFN package, pin 0 is the thermal pad on the package bottom.

Note:

- Unless otherwise specified, all I/Os are configured in input floating mode during and after resets.
- For details about alternate functions, see section "[6.8 Alternate function table](#)".

6.8 Alternate function table

Table 6-2 Alternate function table

Pin	AF0	AF1	AF2	AF3	AF4	AF5	AF6	AF7	AF8	AF9	AF10	AF11	AF12	AF13	AF14	AF15
PA0/AIN0	-	USART1_CTS	TIM2_CH1/TIM2_ETRIN	USART2_CTS	-	LPUART_RX/LPUART_TX	LPTIM_IN1	COMP1_OUT	-	CLU0_O	CLU1_O	CLU2_O	CLU3_O	-	-	-
PA1/AIN1	-	USART1_RTS/USART1_DE	TIM2_CH2	USART2_RTS/USART2_DE	-	TIM15_CH1N	LPTIM_IN2	-	-	CLU0_O	CLU1_O	CLU2_O	CLU3_O	-	-	-
PA2/AIN2	TIM15_CH1	USART1_TX/USART1_RX	TIM2_CH3	USART2_TX/USART2_RX	-	-	LPTIM_ETR	COMP2_OUT	-	CLU0_O	CLU1_O	CLU2_O	CLU3_O	-	-	-
PA3/AIN3	TIM15_CH2	USART1_RX/USART1_TX	TIM2_CH4	USART2_RX/USART2_TX	-	-	LPTIM_OUT	-	-	CLU0_O	CLU1_O	CLU2_O	CLU3_O	-	-	-
PA4/AIN4	SPI1_NSS/I2S1_WS	USART1_CK	-	USART2_CK	TIM14_CH1	-	-	-	-	CLU0_O	CLU1_O	CLU2_O	CLU3_O	-	-	-
PA5/AIN5	SPI1_SCK/I2S1_CK	-	TIM2_CH1/TIM2_ETRIN	-	-	-	-	-	-	CLU0_O	CLU1_O	CLU2_O	CLU3_O	-	-	-
PA6/AIN6	SPI1_MISO/I2S1_MCK	TIM3_CH1	TIM1_BKIN	LPUART_CTS	-	TIM16_CH1	-	COMP1_OUT	-	CLU0_O	CLU1_O	CLU2_O	CLU3_O	-	CAN_RX	-
PA7/AIN7	SPI1_MOSI/I2S1_SD	TIM3_CH2	TIM1_CH1N	-	TIM14_CH1	TIM17_CH1	-	COMP2_OUT	-	CLU0_O	CLU1_O	CLU2_O	CLU3_O	-	CAN_TX	RCC_MC0
PA8	RCC_MC0	USART1_CK	TIM1_CH1	-	-	LPUART_RX/LPUART_TX	-	-	-	-	-	-	-	-	-	-
PA9	TIM15_BKIN	USART1_TX/USART1_RX	TIM1_CH2	LPUART_TX/LPUART_RX	I2C1_SCL	RCC_MC0	-	-	-	-	-	-	-	-	CAN_RX	-
PA10	TIM17_BKIN	USART1_RX/USART1_TX	TIM1_CH3	LPUART_RX/LPUART_TX	I2C1_SDA	-	-	-	-	-	-	-	-	-	CAN_TX	-
PA11	-	USART1_CTS	TIM1_CH4	-	-	I2C2_SCL	-	COMP1_OUT	-	CLU0_O	CLU1_O	CLU2_O	CLU3_O	-	CAN_RX	-
PA12	-	USART1_RTS/USART1_DE	TIM1_ETR	-	-	I2C2_SDA	-	COMP2_OUT	-	CLU0_O	CLU1_O	CLU2_O	CLU3_O	-	CAN_TX	-
PA13	CM0_SW_D	IRTIM_IR_OUT	-	LPUART_RX/LPUART_TX	-	-	-	COMP3_OUT	-	CLU0_O	CLU1_O	CLU2_O	CLU3_O	-	CAN_RX	-

Pin	AF0	AF1	AF2	AF3	AF4	AF5	AF6	AF7	AF8	AF9	AF10	AF11	AF12	AF13	AF14	AF15
PA14	CM0_SW CLK	USART1_ TX/USAR T1_RX	-	LPUART_ TX//LPUA RT_RX	-	USART2_ TX/USAR T2_RX	-	-	-	CLU0_O	CLU1_O	CLU2_O	CLU3_O	-	CAN_TX	-
PA15	SPI1_NSS /I2S1_WS	USART1_ RX/USAR T1_TX	TIM2_CH 1/TIM2_E TRIN	-	-	USART2_ RX/USAR T2_TX	-	-	-	-	-	-	-	-	-	-
PB0/AIN8	-	TIM3_CH 3	TIM1_CH 2N	-	-	-	-	-	-	-	-	-	-	-	-	-
PB1/AIN9	TIM14_C H1	TIM3_CH 4	TIM1_CH 3N	LPUART_ RTS/LPUA RT_DE	-	-	-	COMP3_ OUT	-	CLU0_O	CLU1_O	CLU2_O	CLU3_O	-	-	-
PB2	-	-	-	-	I2C2_SM BA	-	LPTIM_O UT	-	-	-	-	-	-	-	-	I2C1_SM BA
PB3	SPI1_SCK /I2S1_CK	-	TIM2_CH 2	-	-	-	-	COMP3_ OUT	-	-	-	-	-	-	-	-
PB4	SPI1_MIS O/I2S1_ MCK	TIM3_CH 1	-	-	-	TIM17_B KIN	-	-	-	-	-	-	-	-	-	-
PB5	SPI1_MO SI/I2S1_ SD	TIM3_CH 2	TIM16_B KIN	I2C1_SM BA	-	-	LPTIM_IN 1	-	-	-	-	-	-	-	-	-
PB6	USART1_ TX/USAR T1_RX	I2C1_SCL	TIM16_C H1N	LPUART_ TX/LPUA RT_RX	-	-	LPTIM_ET R	-	-	-	-	-	-	-	-	-
PB7	USART1_ RX/USAR T1_TX	I2C1_SDA	TIM17_C H1N	LPUART_ RX/LPUA RT_TX	-	-	LPTIM_IN 2	-	-	-	-	-	-	-	-	-
PB8	-	I2C1_SCL	TIM16_C H1	-	-	-	-	-	-	-	-	-	-	-	CAN_RX	-
PB9	IRTIM_IR OUT	I2C1_SDA	TIM17_C H1	-	-	SPI2_NSS /I2S2_WS	-	-	-	-	-	-	-	-	CAN_TX	-
PB10	-	I2C1_SCL	TIM2_CH 3	LPUART_ TX/LPUA RT_RX	-	SPI2_SCK /I2S2_CK	I2C2_SCL	-	-	-	-	-	-	-	-	-
PB11	-	I2C1_SDA	TIM2_CH 4	LPUART_ RX/LPUA RT_TX	-	-	I2C2_SDA	-	-	-	-	-	-	-	-	-
PB12	SPI1_NSS /I2S1_WS	-	TIM1_BKI N	LPUART_ RTS/LPUA RT_DE	-	TIM15_B KIN	-	-	SPI2_NSS /I2S2_WS	-	-	-	-	-	-	I2C2_SM BA
PB13	SPI1_SCK /I2S1_CK	-	TIM1_CH 1N	LPUART_ CTS	-	I2C2_SCL	-	-	SPI2_SCK /I2S2_CK	-	-	-	-	-	-	-
PB14	SPI1_MIS O/I2C1_ MCK	TIM15_C H1	TIM1_CH 2N	LPUART_ RTS/LPUA RT_DE	-	I2C2_SDA	-	-	SPI2_MIS O/I2S2_ MCK	-	-	-	-	-	-	-

Pin	AF0	AF1	AF2	AF3	AF4	AF5	AF6	AF7	AF8	AF9	AF10	AF11	AF12	AF13	AF14	AF15
PB15	SPI1_MOSI/I2S1_SD	TIM15_CH2	TIM1_CH3N	TIM15_CH1N	-	-	-	-	SPI2_MOSI/I2S2_SD	-	-	-	-	-	-	-
PC0/AIN10	-	-	-	-	-	-	LPTIM_IN1	-	-	-	-	-	-	-	-	-
PC1/AIN11	-	-	-	-	-	-	LPTIM_OUTPUT	-	-	-	-	-	-	-	-	-
PC2/AIN12	-	SPI2_MISO/I2S_MCK	-	-	-	-	LPTIM_IN2	-	-	-	-	-	-	-	-	-
PC3/AIN13	-	SPI2_MOSI/I2S2_SD	-	-	-	-	LPTIM_ETR	-	-	-	-	-	-	-	-	-
PC4/AIN14	-	-	-	LPUART_T/LPUART_RX	-	-	-	-	-	-	-	-	-	-	-	-
PC5/AIN15	-	-	-	LPUART_RX/LPUART_TX	-	-	-	-	-	-	-	-	-	-	-	-
PC6	TIM3_CH1	-	-	-	-	-	LPTIM_IN1	-	-	-	-	-	-	-	-	-
PC7	TIM3_CH2	-	-	-	-	-	LPTIM_OUTPUT	-	-	-	-	-	-	-	-	-
PC8	TIM3_CH3	-	-	-	-	-	LPTIM_IN2	-	-	-	-	-	-	-	-	-
PC9	TIM3_CH4	-	-	-	-	-	LPTIM_ETR	-	-	-	-	-	-	-	-	-
PC10	-	-	-	LPUART_TX/LPUART_RX	-	-	LPTIM_IN1	-	-	CLU0_O	CLU1_O	CLU2_O	CLU3_O	-	-	-
PC11	-	-	-	LPUART_RX/LPUART_TX	-	-	LPTIM_OUTPUT	-	-	CLU0_O	CLU1_O	CLU2_O	CLU3_O	-	CAN_RX	-
PC12	-	-	-	-	-	-	LPTIM_IN2	-	-	CLU0_O	CLU1_O	CLU2_O	CLU3_O	-	CAN_TX	-
PD2	TIM3_ETR	-	-	LPUART_RTS/LPUART_DE	-	-	LPTIM_ETR	-	-	-	-	-	-	-	-	-
PF0	-	I2C1_SDA	-	-	-	-	-	-	-	-	-	-	-	-	-	-
PF1	-	I2C1_SCL	-	-	-	-	-	-	-	-	-	-	-	-	-	-
PF4	-	-	-	-	-	-	-	-	-	-	-	-	-	-	-	-
PF5	-	-	-	-	-	-	-	-	-	-	-	-	-	-	-	-
PF6	-	I2C1_SCL	-	-	-	-	I2C2_SCL	-	-	-	-	-	-	-	-	-
PF7	-	I2C1_SDA	-	-	-	-	I2C2_SDA	-	-	-	-	-	-	-	-	-

7 Package characteristics

7.1 TSSOP20

TSSOP20 is a 6.5 mm × 6.5 mm, 0.65 mm pitch package.

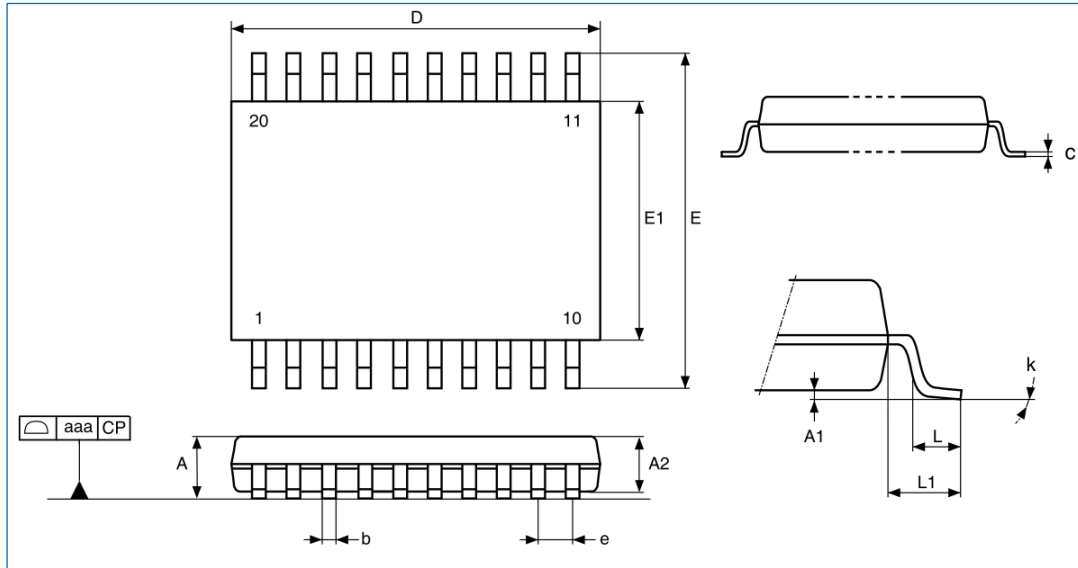

Figure 7-1 TSSOP20 package outline

Table 7-1 TSSOP20 package parameters

	Min (mm)	Typ (mm)	Max (mm)	Min (inches) ⁽¹⁾	Typ (inches) ⁽¹⁾	Max (inches) ⁽¹⁾
A	-	-	1.200	-	-	0.0472
A1	0.050	-	0.150	0.0020	-	0.0059
A2	0.800	1.000	1.050	0.0315	0.0394	0.0413
b	0.190	-	0.300	0.0075	-	0.0118
c	0.090	-	0.200	0.0035	-	0.0079
D	6.400	6.500	6.600	0.2520	0.2559	0.2598
E	6.200	6.400	6.600	0.2441	0.2520	0.2598
E1	4.300	4.400	4.500	0.1693	0.1732	0.1772
e	-	0.650	-	-	0.0256	-
L	0.450	0.600	0.750	0.0177	0.0236	0.0295
L1	-	1.000	-	-	0.0394	-
k	0°	-	8.0°	0°	-	8.0°
aaa	-	-	0.1000	-	-	0.0039

(1). The values in inches are converted from the values in millimeters and rounded to four decimal places.

7.2 QNF28

QNF28 is a 4 mm × 4 mm, 0.4 mm pitch package.

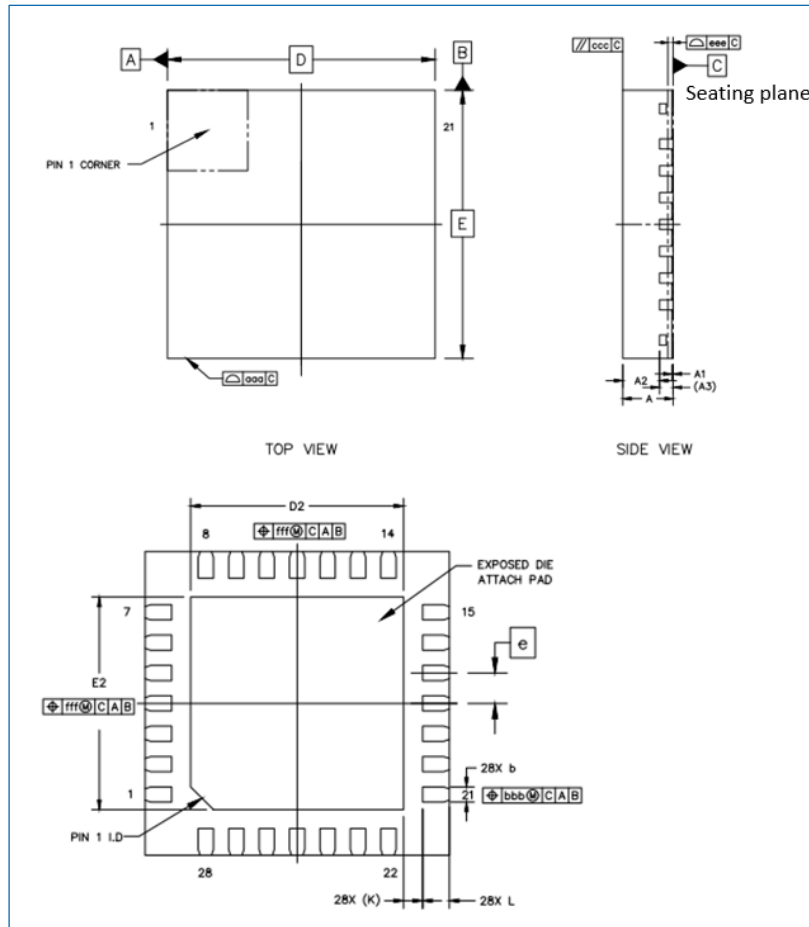

Figure 7-2 QNF28 package outline

Table 7-2 QNF28 package parameters

Symbol	Min (mm)	Typ (mm)	Max (mm)
A	0.7	0.75	0.8
A1	0	0.02	0.05
A2	-	0.55	-
A3	0.203 REF ⁽¹⁾		
b	0.15	0.20	0.25
D	4 BSC ⁽²⁾		
E	4 BSC		
e	0.4 BSC		
D2	2.7	2.9	2.9
E2	2.7	2.9	2.9
L	0.3	0.35	0.4
K	0.25 REF		
aaa	0.1		
ccc	0.1		
eee	0.08		
bbb	0.1		
fff	0.1		

(1). REF indicates a reference value.

(2). BSC: basic spacing between centers.

7.3 QFN32

QFN32 is a 5 mm × 5 mm, 0.5 mm pitch package.

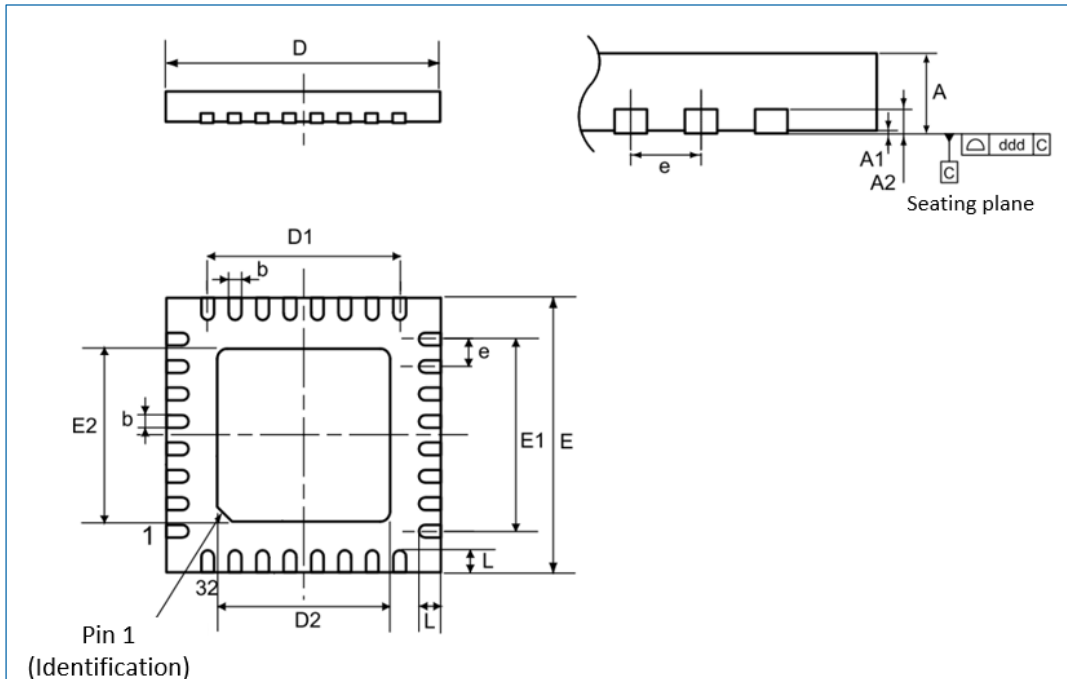

Figure 7-3 QFN32 package outline

Table 7-3 QFN32 package parameters

Symbol	Min (mm)	Typ (mm)	Max (mm)	Min (inches) ⁽¹⁾	Typ (inches) ⁽¹⁾	Max (inches) ⁽¹⁾
A	0.500	0.550	0.600	0.0197	0.0217	0.0236
A1	0.500	0.550	0.600	0.0197	0.0217	0.0236
A2	0.000	0.020	0.050	0.0000	0.0008	0.0020
A3	-	0.152	-	-	0.0060	-
b	0.180	0.230	0.280	0.0071	0.0091	0.0110
D	4.900	5.000	5.100	0.1929	0.1969	0.2008
D1	3.400	3.500	3.600	0.1339	0.1378	0.1417
D2	3.400	3.500	3.600	0.1339	0.1378	0.1417
E	4.900	5.000	5.100	0.1929	0.1969	0.2008
E1	3.400	3.500	3.600	0.1339	0.1378	0.1417
E2	3.400	3.500	3.600	0.1339	0.1378	0.1417
e	-	0.500	-	-	0.0197	-
L	0.300	0.400	0.500	0.0118	0.0157	0.0197
ddd	-	-	0.080	-	-	0.0031

(1). The values in inches are converted from the values in millimeters and rounded to four decimal places.

7.4 LQFP32

LQFP32 is a 7 mm × 7 mm, 0.8 mm pitch package.

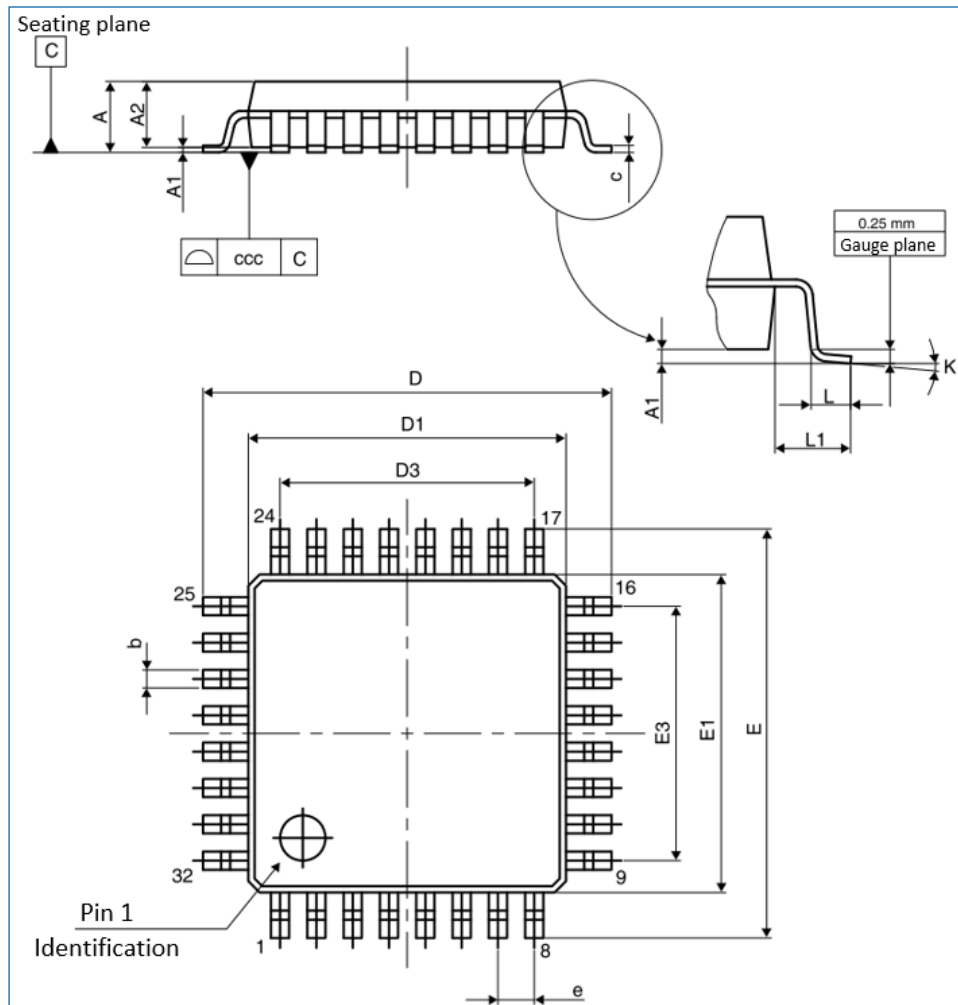

Figure 7-4 LQFP32 package outline

Table 7-4 LQFP32 package parameters

Symbol	Min (mm)	Typ (mm)	Max (mm)	Min (inches) ⁽¹⁾	Typ (inches) ⁽¹⁾	Max (inches) ⁽¹⁾
A	-	-	1.600	-	-	0.0630
A1	0.050	-	0.150	0.0020	-	0.0059
A2	1.350	1.400	1.450	0.0531	0.0551	0.0571
b	0.300	0.370	0.450	0.0118	0.0146	0.0177
c	0.090	-	0.200	0.0035	-	0.0079
D	8.800	9.000	9.200	0.3465	0.3543	0.3622
D1	6.800	7.000	7.200	0.2677	0.2756	0.2835
D3	-	5.600	-	-	0.2205	-
E	8.800	9.000	9.200	0.3465	0.3543	0.3622
E1	6.800	7.000	7.200	0.2677	0.2756	0.2835
E3	-	5.600	-	-	0.2205	-
e	-	0.800	-	-	0.0315	-
K	0°	3.5°	7°	0°	3.5°	7°
L	0.450	0.600	0.750	0.0177	0.0236	0.0295
L1	-	1.000	-	-	0.0394	-
ccc	-	-	0.100	-	-	0.0039

(1). The values in inches are converted from the values in millimeters and rounded to four decimal places.

7.5 LQFP48

LQFP48 is a 7 mm × 7 mm, 0.5 mm pitch package.

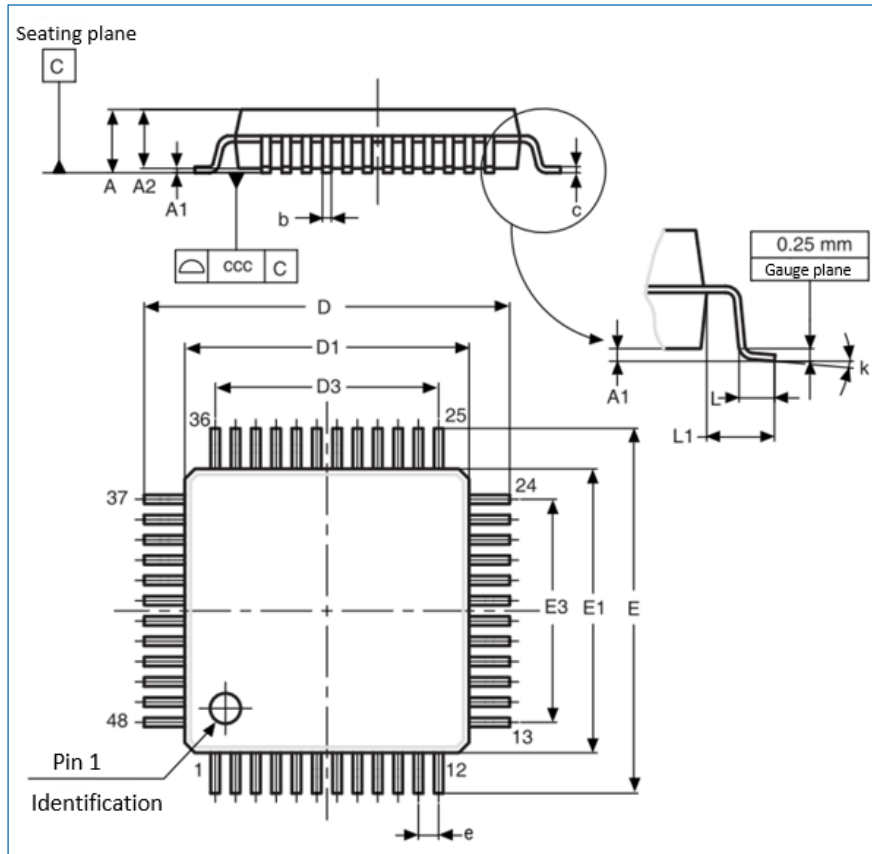

Figure 7-5 LQFP48 package outline

Table 7-5 LQFP48 package parameters

Symbol	Min (mm)	Typ (mm)	Max (mm)	Min (inches) ⁽¹⁾	Typ (inches) ⁽¹⁾	Max (inches) ⁽¹⁾
A	-	-	1.600	-	-	0.0630
A1	0.050	-	0.150	0.0020	-	0.0059
A2	1.350	1.400	1.450	0.0531	0.0551	0.0571
b	0.170	0.220	0.270	0.0067	0.0087	0.0106
c	0.090	-	0.200	0.0035	-	0.0079
D	8.800	9.000	9.200	0.3465	0.3543	0.3622
D1	6.800	7.000	7.200	0.2677	0.2756	0.2835
D3	-	5.500	-	-	0.2165	-
E	8.800	9.000	9.200	0.3465	0.3543	0.3622
E1	6.800	7.000	7.200	0.2677	0.2756	0.2835
E3	-	5.500	-	-	0.2165	-
e	-	0.500	-	-	0.0197	-
L	0.450	0.600	0.750	0.0177	0.0236	0.0295
L1	-	1.000	-	-	0.0394	-
k	0°	3.5°	7°	0°	3.5°	7°
ccc	0.080	-	-	0.0031	-	-

(1). The values in inches are converted from the values in millimeters and rounded to four decimal places.

7.6 LQFP64

LQFP64 is a 10 mm × 10 mm, 0.5 mm pitch package.

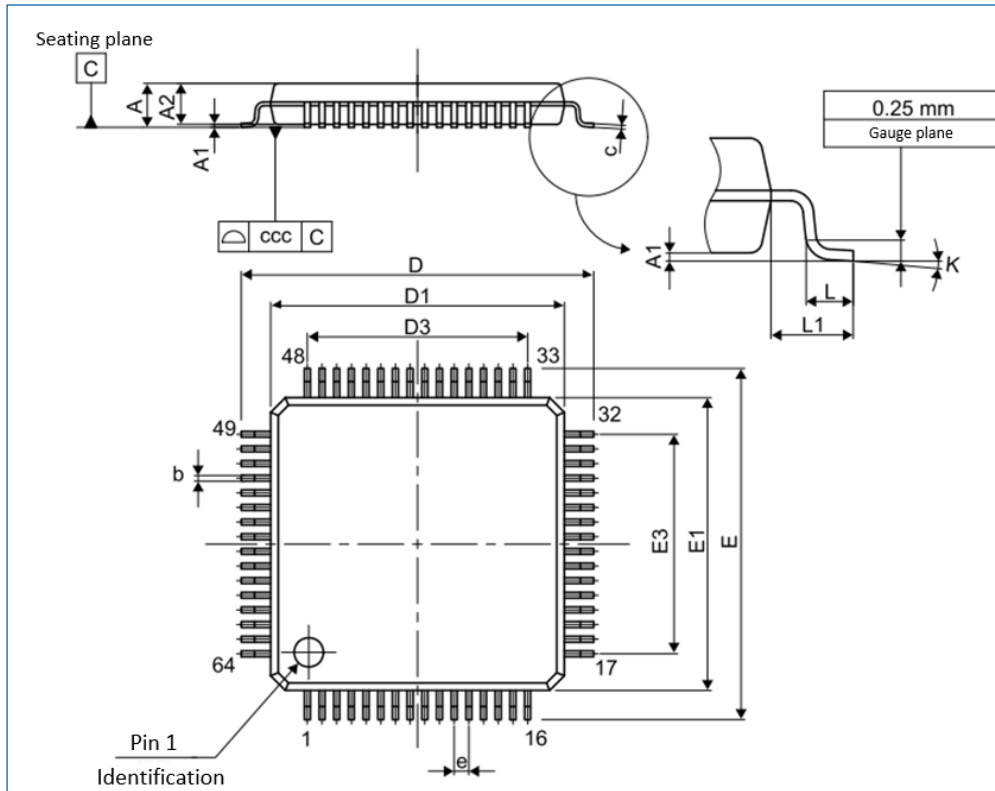

Figure 7-6 LQFP64 package outline

Table 7-6 LQFP64 package parameters

Symbol	Min (mm)	Typ (mm)	Max (mm)	Min (inches) ⁽¹⁾	Typ (inches) ⁽¹⁾	Max (inches) ⁽¹⁾
A	-	-	1.600	-	-	0.0630
A1	0.050	-	0.150	0.0020	-	0.0059
A2	1.350	1.400	1.450	0.0531	0.0551	0.0571
b	0.170	0.220	0.270	0.0067	0.0087	0.0106
c	0.090	-	0.200	0.0035	-	0.0079
D	-	12.000	-	-	0.4724	-
D1	-	10.000	-	-	0.3937	-
D3	-	7.500	-	-	0.2953	-
E	-	12.000	-	-	0.4724	-
E1	-	10.000	-	-	0.3937	-
E3	-	7.500	-	-	0.2953	-
e	-	0.500	-	-	0.0197	-
K	0°	3.5°	7°	0°	3.5°	7°
L	0.450	0.600	0.750	0.0177	0.0236	0.0295
L1	-	1.000	-	-	0.0394	-
ccc	-	-	0.080	-	-	0.0031

(1). The values in inches are converted from the values in millimeters and rounded to four decimal places.

8 Ordering information

Table 8-1 HK32ASPIN010xB ordering information

Package Type	Part Number	Shipping Option	Remarks
TSSOP20	HK32ASPIN010FBP6	Tape and reel/Tube	-
QFN28	HK32ASPIN010GBU6	Tape and reel/Tray	-
QFN32	HK32ASPIN010KBU6	Tape and reel/Tray	
LQFP32	HK32ASPIN010KBT6	Tape and reel/Tray	
LQFP48	HK32ASPIN010CBT6	Tape and reel/Tray	
LQFP64	HK32ASPIN010RBT6	Tape and reel/Tray	

9 Acronyms

Term	Full Name
ADC	Analog-to-Digital Converter
AHB	Advanced High-performance Bus
APB	Advanced Peripheral Bus
AWU	Auto-wakeup Unit
CLU	Configurable Logic Unit
CRC	Cyclic Redundancy Check
CSS	Clock Security System
CTS	Clear to Send
DMA	Direct Memory Access
EMACC	Electric Motor Acceleration
EXTI	Extended Interrupt/Event Controller
GPIO	General-purpose Input/Output
HSE	High Speed External (Clock Signal)
I2C	Inter-Integrated Circuit
I2S	Inter-IC Sound
IWDG	Independent Watchdog
LSI	Low Speed Internal (clock signal)
MCU	Microcontroller Unit
MSPS	Million Samples Per Second
NVIC	Nested Vectored Interrupt Controller
PDR	Power-down Reset
PLL	Phase-locked Loop
POR	Power-on Reset
PPM	Parts per Million
PWM	Pulse Width Modulation
RCC	Reset and Clock Control
RISC	Reduced Instruction Set Computer
RTS	Request to Send
SPI	Serial Peripheral Interface
SRAM	Static Random Access Memory
SWD	Serial Wire Debug
USART	Universal Synchronous/Asynchronous Receiver/Transmitter
WWDG	Window Watchdog

10 Legal and contact information



航顺芯片 and other Hangshun trademarks are trademarks of Shenzhen Hangshun Chip Technology R&D Co., Ltd. (hereinafter referred to as Hangshun). All other trademarks or trade names mentioned in this document are the property of their respective holders.

No part or sub-part of Hangshun product specifications and datasheets may be modified in any form or by any means without consent. Hangshun reserves the right to modify the datasheets and/or products, discontinue any product, or terminate any service without notice. It is recommended that customers obtain relevant information of the latest version and verify that the information is up-to-date and complete before placing an order. All products are sold in accordance with the terms of the sales contract provided at the time of order confirmation. The terms include the scope of warranty, intellectual property rights, and responsibility.

Hangshun guarantees the performance of Hangshun products in accordance with Hangshun's standards during the sales period. Hangshun believes it is necessary to support this warranty by using testing and other quality control techniques. Unless mandatory government regulations are brought in, special tests or measurements by using other instruments are unnecessary.

The customer acknowledges that Hangshun products are not designed or manufactured for purposes related to life support, or for systems or products in dangerous activities or environments. Malfunctioning products may cause personal injuries, deaths, or damage to property or environments (collectively referred to as high-risk activities). The Hangshun products that are used in high-risk activities are not under warranty. Hangshun assumes no liability for customers or third parties involved therein.

Hangshun will provide the same technical support, help, advice, and information as it does now (including the design, development, or debugging of the purchased circuit boards or other applications). Hangshun makes no guarantee and assumes no legal liability for all support technologies, merchantability, or fitness for a particular purpose if the support technologies are error-free and circuit boards and other applications can operate normally.

Copyright © Shenzhen Hangshun Chip Technology R&D Co., Ltd. 2015-2023

Shenzhen Hangshun Chip Technology R&D Co., Ltd.

TEL: +86-755-83247667

Website: www.hsxp-hk.com