



Features

- Operating voltage: 2.7V~5.2V
- Built-in RC oscillator
- 1/4 bias, 1/8 duty, frame frequency is 64Hz
- Max. 32×8 patterns, 8 commons, 32 segments
- Built-in internal resistor type bias generator
- 3-wire serial interface
- 8 kinds of time base or WDT selection
- Time base or WDT overflow output
- Built-in LCD display RAM
- R/W address auto increment
- Two selectable buzzer frequencies (2kHz or 4kHz)
- Power down command reduces power consumption
- Software configuration feature
- Data mode and Command mode instructions
- Three data accessing modes
- VLCD pin to adjust LCD operating voltage
- 44/52-pin QFP, 44/64-pin LQFP packages
HT1622G: Gold bumped chip

General Description

HK1622 is a peripheral device specially designed for I/O type MCU used to expand the display capability. The max. display segment of the device are 256 patterns (32×8). It also supports serial interface, buzzer sound, Watchdog Timer or time base timer functions. The HK1622 is a memory mapping and multi-function LCD

controller. The software configuration feature of the HK1622 makes it suitable for multiple LCD applications including LCD modules and display subsystems. Only three lines are required for the interface between the host controller and the HK1622. The HK162X series have many kinds of products that match various applications.

Selection Table

HK162X	HK1620	HK1621	HK1622	HK16220	HK1623	HK1625	HK1626
COM	4	4	8	8	8	8	16
SEG	32	32	32	32	48	64	48
Built-in Osc.	—	√	√	—	√	√	√
Crystal Osc.	√	√	—	√	√	√	√

Block Diagram

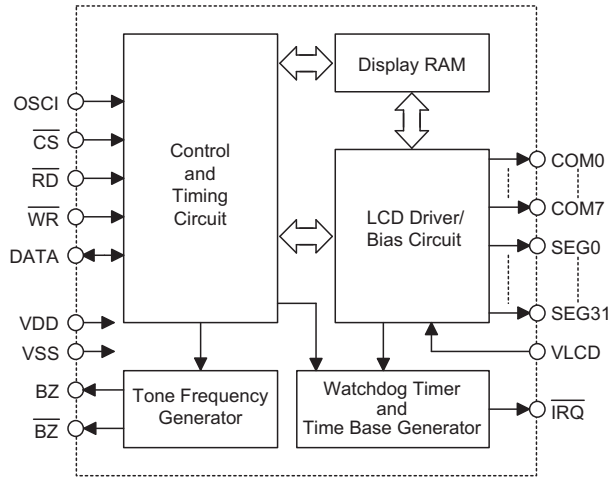

Pin Assignment

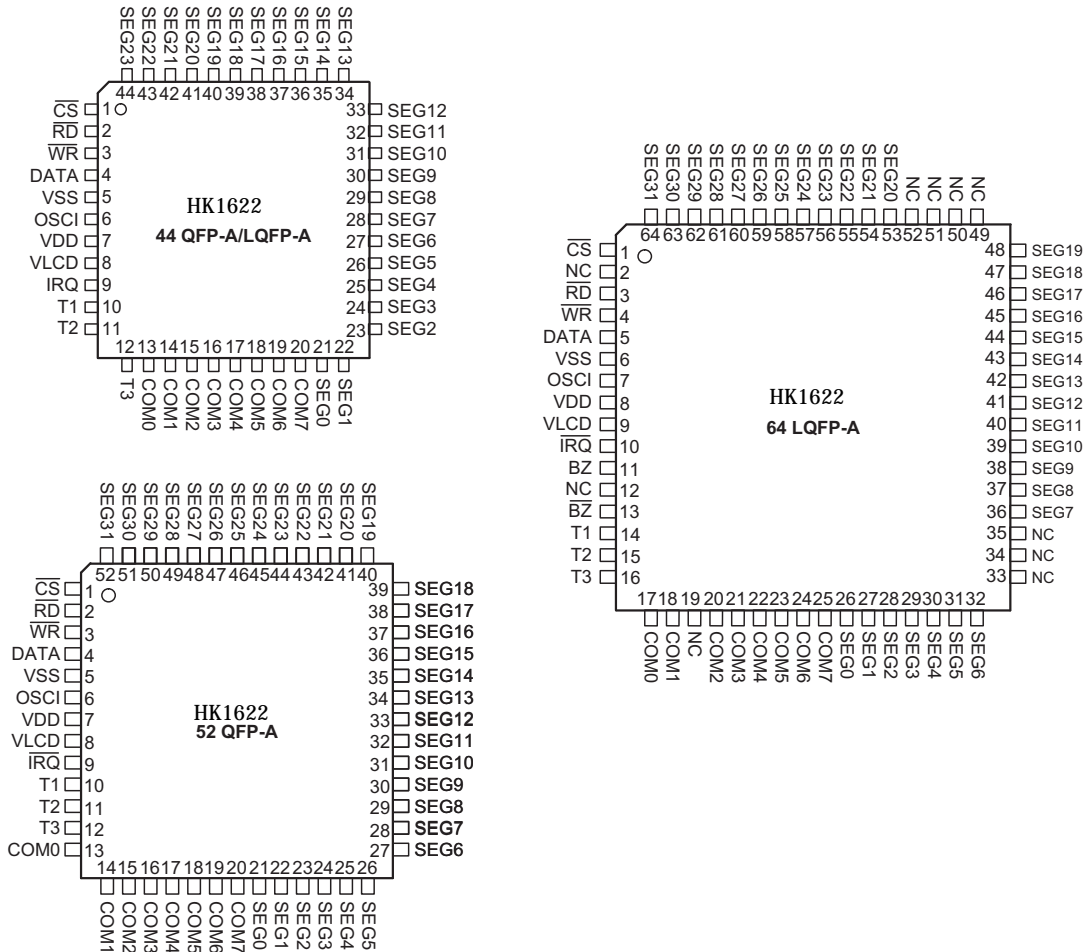

Pad Assignment

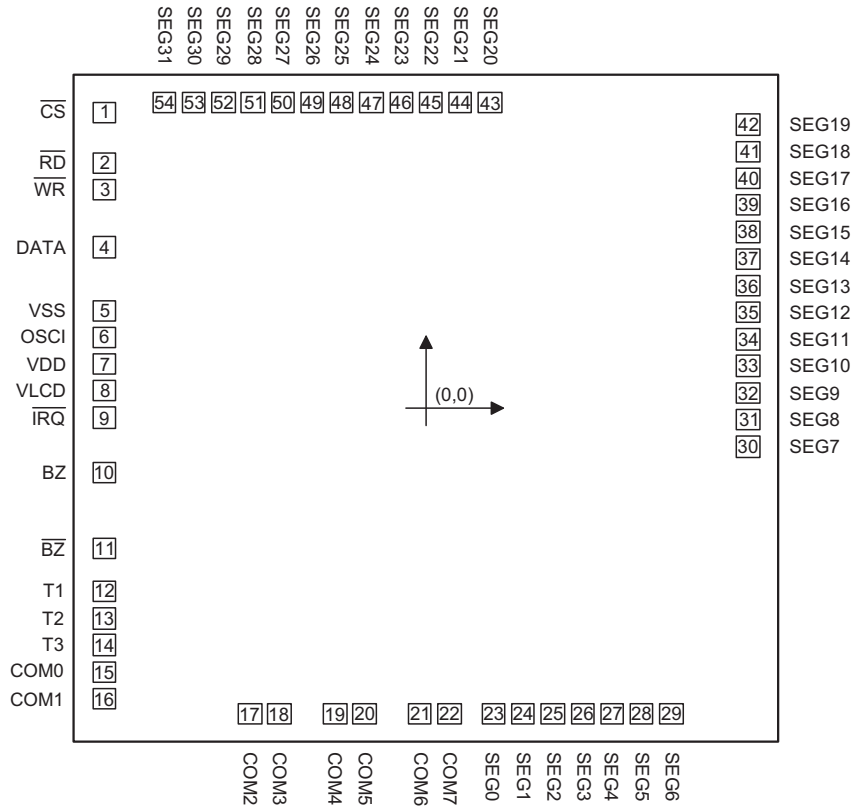

Chip size: $94 \times 98 \text{ (mil)}^2$

Bump height: $18\mu\text{m} \pm 3\mu\text{m}$

Min. Bump spacing: $23.102\mu\text{m}$

Bump size: $76 \times 76\mu\text{m}^2$

* The IC substrate should be connected to VDD in the PCB layout artwork.

Pad Coordinates

Unit: μm

Pad No.	X	Y	Pad No.	X	Y
1	-1077.075	1090.589	28	721.077	-1129.575
2	-1077.075	905.211	29	820.095	-1129.575
3	-1077.075	806.109	30	1076.900	-141.904
4	-1077.075	594.542	31	1076.900	-42.885
5	-1077.037	359.680	32	1076.900	56.215
6	-1077.075	260.745	33	1076.900	155.234
7	-1077.037	162.710	34	1076.900	254.335
8	-1077.075	63.734	35	1076.900	353.354
9	-1077.075	-34.789	36	1076.900	452.456
10	-1077.075	-238.247	37	1076.900	551.474
11	-1077.075	-519.705	38	1076.900	650.576
12	-1077.075	-677.315	39	1076.900	749.594
13	-1077.075	-776.416	40	1076.900	848.695
14	-1077.075	-875.435	41	1076.900	947.714
15	-1077.075	-974.536	42	1076.900	1046.816
16	-1077.075	-1073.554	43	213.669	1127.150
17	-589.281	-1129.575	44	114.650	1127.150
18	-490.179	-1129.575	45	15.550	1127.150
19	-304.799	-1129.575	46	-83.469	1127.150
20	-205.699	-1129.575	47	-182.570	1127.150
21	-20.319	-1129.575	48	-281.590	1127.150
22	78.736	-1129.575	49	-380.690	1127.150
23	225.736	-1129.575	50	-479.710	1127.150
24	324.836	-1129.575	51	-578.810	1127.150
25	423.856	-1129.575	52	-677.829	1127.150
26	522.957	-1129.575	53	-776.931	1127.150
27	621.975	-1129.575	54	-875.949	1127.150

Pad Description

Pad No.	Pad Name	I/O	Description
1	$\overline{\text{CS}}$	I	Chip selection input with Pull-high resistor. When the $\overline{\text{CS}}$ is logic high, the data and command read from or written to the HK1622 are disabled. These serial interface circuit is also reset. But if $\overline{\text{CS}}$ is at logic low level and is input to the $\overline{\text{CS}}$ pad, the data and command transmission between the host controller and the HT1622 are all enabled.
2	$\overline{\text{RD}}$	I	READ clock input with Pull-high resistor. Data in the RAM of the HK1622 are clocked out on the falling edge of the RD signal. The clocked out data will appear on the data line. The host controller can use the next rising edge to latch the clocked out data.
3	$\overline{\text{WR}}$	I	WRITE clock input with Pull-high resistor. Data on the DATA line are latched into the HK1622 on the rising edge of the $\overline{\text{WR}}$ signal.
4	DATA	I/O	Serial data input or output with Pull-high resistor
5	VSS	—	Negative power supply, ground
6	OSCI	I	If the system clock comes from an external clock source, the external clock source should be connected to the OSCI pad.
7	VDD	—	Positive power supply
8	VLCD	I	LCD operating voltage input pad
9	$\overline{\text{IRQ}}$	O	Time base or Watchdog Timer overflow flag, NMOS open drain output
10, 11	BZ, $\overline{\text{BZ}}$	O	2kHz or 4kHz tone frequency output pair
12~14	T1~T3	I	Not connected
15~22	COM0~COM7	O	LCD common outputs
23~54	SEG0~SEG31	O	LCD segment outputs

Absolute Maximum Ratings

Supply Voltage	$V_{SS}-0.3V$ to $V_{SS}+5.5V$	Storage Temperature	$-50^{\circ}C$ to $125^{\circ}C$
Input Voltage	$V_{SS}-0.3V$ to $V_{DD}+0.3V$	Operating Temperature	$-40^{\circ}C$ to $85^{\circ}C$

Note: These are stress ratings only. Stresses exceeding the range specified under "Absolute Maximum Ratings" may cause substantial damage to the device. Functional operation of this device at other conditions beyond those listed in the specification is not implied and prolonged exposure to extreme conditions may affect device reliability.

D.C. Characteristics

$T_a=25^{\circ}C$

Symbol	Parameter	Test Conditions		Min.	Typ.	Max.	Unit
		V_{DD}	Conditions				
V_{DD}	Operating Voltage	—	—	2.7	—	5.2	V
I_{DD1}	Operating Current	3V	No load/LCD ON On-chip RC oscillator	—	80	210	μA
		5V		—	135	415	μA
I_{DD2}	Operating Current	3V	No load/LCD OFF On-chip RC oscillator	—	8	30	μA
		5V		—	20	55	μA
I_{STB}	Standby Current	3V	No load, Power Down Mode	—	1	8	μA
		5V		—	2	16	μA
V_{IL}	Input Low Voltage	3V	DATA, \overline{WR} , \overline{CS} , \overline{RD}	0	—	0.6	V
		5V		0	—	1.0	V
V_{IH}	Input High Voltage	3V	DATA, \overline{WR} , \overline{CS} , \overline{RD}	2.4	—	3.0	V
		5V		4.0	—	5.0	V
I_{OL1}	BZ, \overline{BZ} , \overline{IRQ}	3V	$V_{OL}=0.3V$	0.9	1.8	—	mA
		5V	$V_{OL}=0.5V$	1.7	3.0	—	mA
I_{OH1}	BZ, \overline{BZ}	3V	$V_{OH}=2.7V$	-0.9	-1.8	—	mA
		5V	$V_{OH}=4.5V$	-1.7	-3.0	—	mA
I_{OL2}	DATA	3V	$V_{OL}=0.3V$	200	450	—	μA
		5V	$V_{OL}=0.5V$	250	500	—	μA
I_{OH2}	DATA	3V	$V_{OH}=2.7V$	-200	-450	—	μA
		5V	$V_{OH}=4.5V$	-250	-500	—	μA
I_{OL3}	LCD Common Sink Current	3V	$V_{OL}=0.3V$	15	40	—	μA
		5V	$V_{OL}=0.5V$	100	200	—	μA
I_{OH3}	LCD Common Source Current	3V	$V_{OH}=2.7V$	-15	-30	—	μA
		5V	$V_{OH}=4.5V$	-45	-90	—	μA
I_{OL4}	LCD Segment Sink Current	3V	$V_{OL}=0.3V$	15	30	—	μA
		5V	$V_{OL}=0.5V$	70	150	—	μA
I_{OH4}	LCD Segment Source Current	3V	$V_{OH}=2.7V$	-6	-13	—	μA
		5V	$V_{OH}=4.5V$	-20	-40	—	μA
R_{PH}	Pull-high Resistor	3V	DATA, \overline{WR} , \overline{CS} , \overline{RD}	100	200	300	k Ω
		5V		50	100	150	k Ω

A.C. Characteristics

Ta=25°C

Symbol	Parameter	Test Conditions		Min.	Typ.	Max.	Unit
		V _{DD}	Conditions				
f _{SYS}	System Clock	3V	On-chip RC oscillator	24	32	40	kHz
		5V					
		—	External clock source	—	32768	—	Hz
f _{LCD}	LCD Frame Frequency	3V	On-chip RC oscillator	48	64	80	Hz
		5V					
		—	External clock source	—	64	—	Hz
t _{COM}	LCD Common Period	—	n: Number of COM	—	n/f _{LCD}	—	sec
f _{CLK1}	Serial Data Clock (\overline{WR} pin)	3V	Duty cycle 50%	4	—	150	kHz
		5V					
f _{CLK2}	Serial Data Clock (\overline{RD} pin)	3V	Duty cycle 50%	—	—	75	kHz
		5V					
t _{CS}	Serial Interface Reset Pulse Width (Figure 3)	—	\overline{CS}	500	600	—	ns
t _{CLK}	\overline{WR} , \overline{RD} Input Pulse Width (Figure 1)	3V	Write mode	3.34	—	125	μs
			Read mode	6.67	—	—	
		5V	Write mode	1.67	—	125	μs
			Read mode	3.34	—	—	
t _r , t _f	Rise/Fall Time Serial Data Clock Width (Figure 1)	—	—	—	120	160	ns
t _{su}	Setup Time for DATA to \overline{WR} , \overline{RD} Clock Width (Figure 2)	—	—	60	120	—	ns
t _h	Hold Time for DATA to \overline{WR} , \overline{RD} , Clock Width (Figure 2)	—	—	500	600	—	ns
t _{su1}	Setup Time for \overline{CS} to \overline{WR} , \overline{RD} Clock Width (Figure 3)	—	—	500	600	—	ns
t _{h1}	Hold Time for \overline{CS} to \overline{WR} , \overline{RD} Clock Width (Figure 3)	—	—	50	100	—	ns
f _{TONE}	Tone Frequency (2kHz)	3V	On-chip RC oscillator	1.5	2.0	2.5	kHz
		5V					
	Tone Frequency (4kHz)	3V	On-chip RC oscillator	3	4	5	kHz
		5V					
t _{OFF}	V _{DD} OFF Times (Figure 4)	—	V _{DD} drop down to 0V	20	—	—	ms
t _{SR}	V _{DD} Rising Slew Rate (Figure 4)	—	—	0.05	—	—	V/ms
t _{RSTD}	Delay Time after Reset (Figure 4)	—	—	1	—	—	ms

- Note:
1. If the conditions of Power-on Reset timing are not satisfied in power On/Off sequence, the internal Power-on Reset (POR) circuit will not operate normally.
 2. If the V_{DD} drops below the minimum voltage of operating voltage spec. during operating, the conditions of Power-on Reset timing must be satisfied also. That is, the V_{DD} must drop to 0V and keep at 0V for 20ms (min.) before rising to the normal operating voltage.

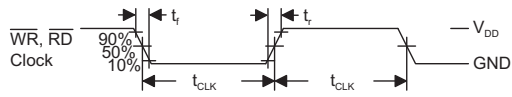

Figure 1

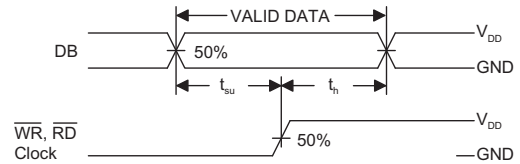

Figure 2

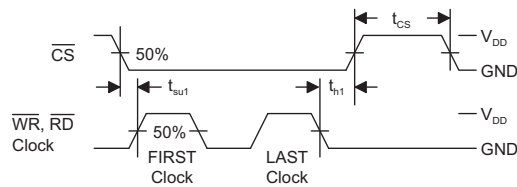

Figure 3

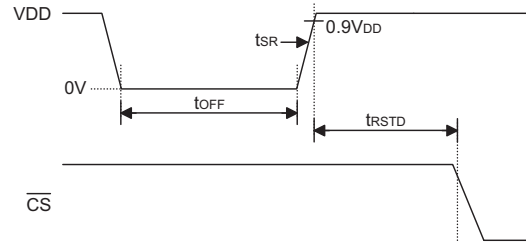

Figure 4. Power-on Reset Timing

RC Oscillator Frequency Deviation

Operating Temperature	-40°C	0°C	25°C	70°C	75°C	80°C	85°C
Average Deviation	19.85%	2.98%	0	-21.14%	-22.50%	-23.82%	-25.35%

Functional Description

Display Memory – RAM Structure

The static display RAM is organized into 64x4 bits and stores the display data. The contents of the RAM are directly mapped to the contents of the LCD driver. Data in the RAM can be accessed by the READ, WRITE and READ-MODIFY-WRITE commands. The following is a mapping from the RAM to the LCD patterns.

Time Base and Watchdog Timer (WDT)

The time base generator and WDT share the same divided ($\div 256$) counter. TIMER DIS/EN/CLR, WDT DIS/EN/CLR and $\overline{\text{IRQ EN/DIS}}$ are independent from each other. Once the WDT time-out occurs, the $\overline{\text{IRQ}}$ pin will

remain at logic low level until the CLR WDT or the $\overline{\text{IRQ DIS}}$ command is issued.

If an external clock is selected as the source of system frequency, the SYS DIS command turns out invalid and the power down mode fails to be carried out until the external clock source is removed.

Buzzer Tone Output

A simple tone generator is implemented in the HK1622.

The tone generator can output a pair of differential driving signals on the BZ and $\overline{\text{BZ}}$ which are used to generate a single tone.

	COM7	COM6	COM5	COM4	COM3	COM2	COM1	COM0	
SEG0				1					0
SEG1				3					2
SEG2				5					4
SEG3				7					6
...
SEG31				63					62
	D3	D2	D1	D0	D3	D2	D1	D0	
	Addr Data				Addr Data				

Data 4 Bits
(D3, D2, D1, D0)

Address 6 Bits
(A5, A4, ..., A0)

RAM Mapping

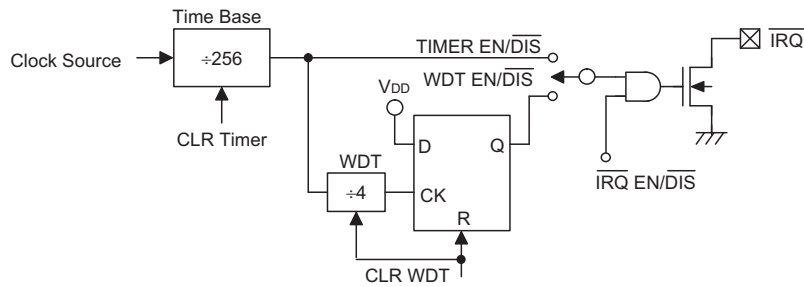

Timer and WDT Configurations

Command Format

The HK1622 can be configured by the software setting. There are two mode commands to configure the HK1622 resource and to transfer the LCD display data.

The following are the data mode ID and the command mode ID:

Operation	Mode	ID
READ	Data	1 1 0
WRITE	Data	1 0 1
READ-MODIFY-WRITE	Data	1 0 1
COMMAND	Command	1 0 0

If successive commands have been issued, the command mode ID can be omitted. While the system is operating in a non-successive command or a non-successive address data mode, the \overline{CS} pin should be set to "1" and the previous operation mode will be reset also. The \overline{CS} pin returns to "0", a new operation mode ID should be issued first.

Name	Command Code	Function
TONE OFF	0000-1000-X	Turn-off tone output
TONE 4K	010X-XXXX-X	Turn-on tone output, tone frequency is 4kHz
TONE 2K	0110-XXXX-X	Turn-on tone output, tone frequency is 2kHz

Timing Diagrams

READ Mode (Command Code : 1 1 0)

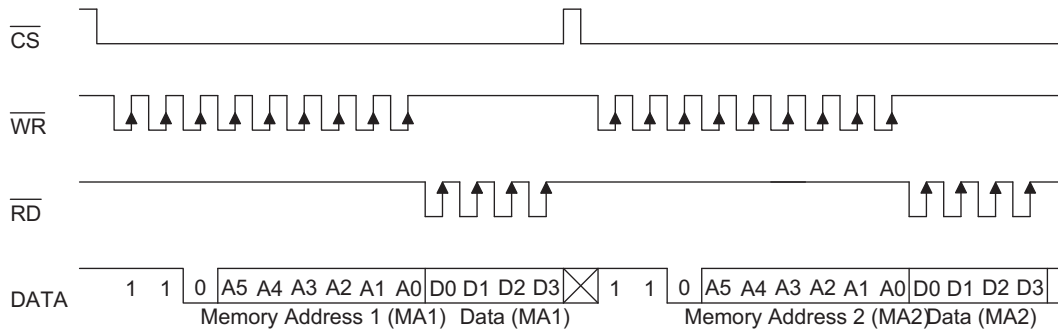

READ Mode (Successive Address Reading)

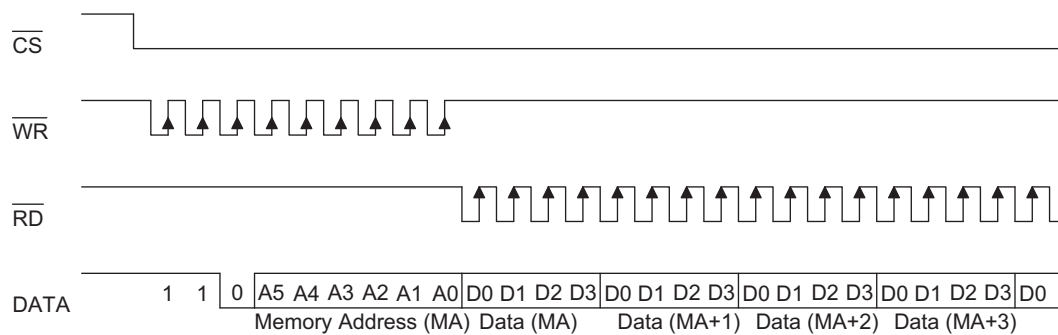

WRITE Mode (Command Code : 1 0 1)

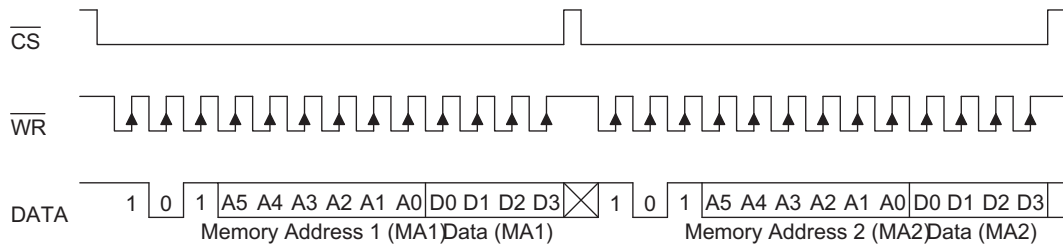

WRITE Mode (Successive Address Writing)

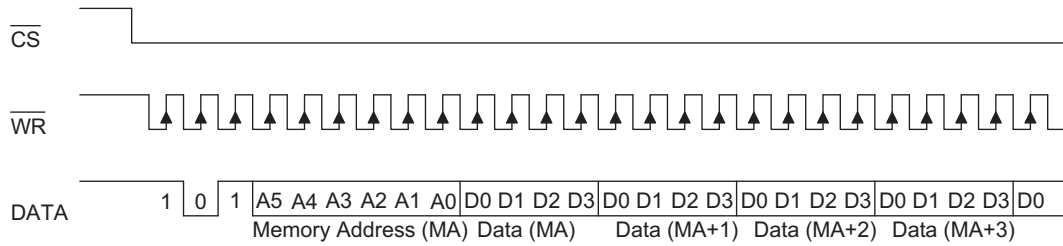

READ-MODIFY-WRITE Mode (Command Code : 1 0 1)

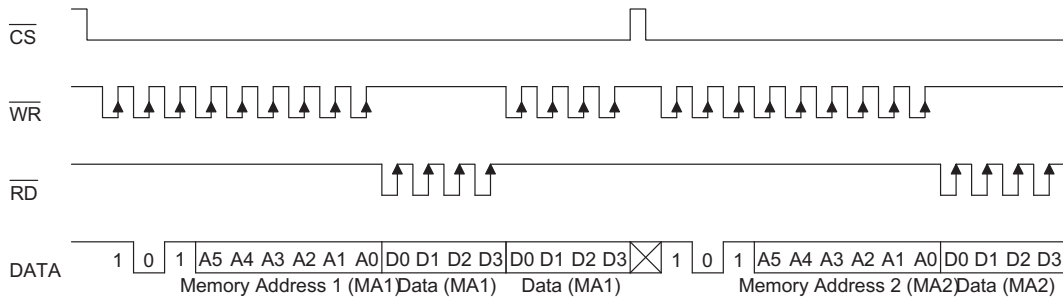

READ-MODIFY-WRITE Mode (Successive Address Accessing)

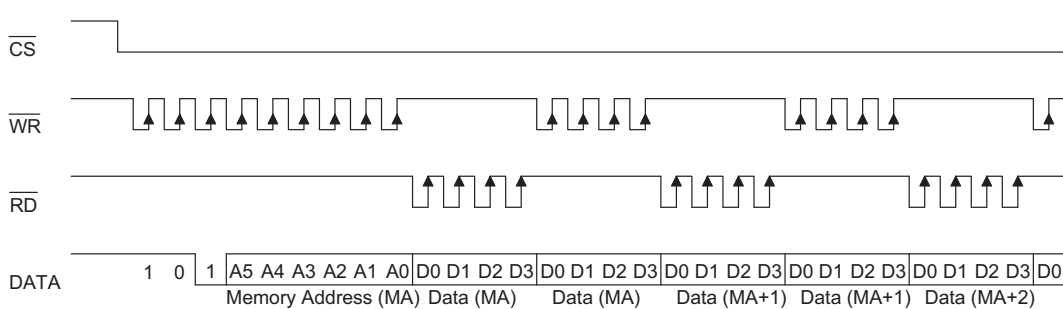

Command Mode (Command Code : 1 0 0)

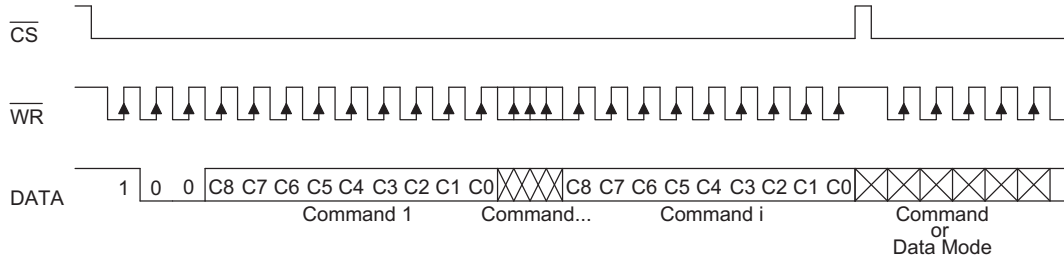

Mode (Data and Command Mode)

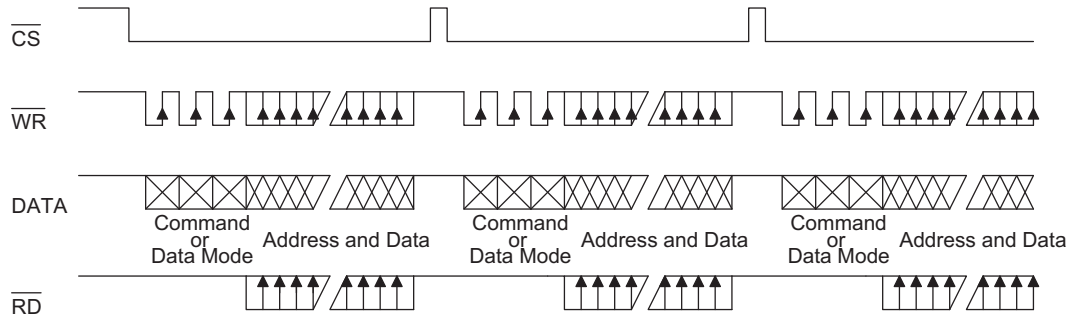

Application Circuits

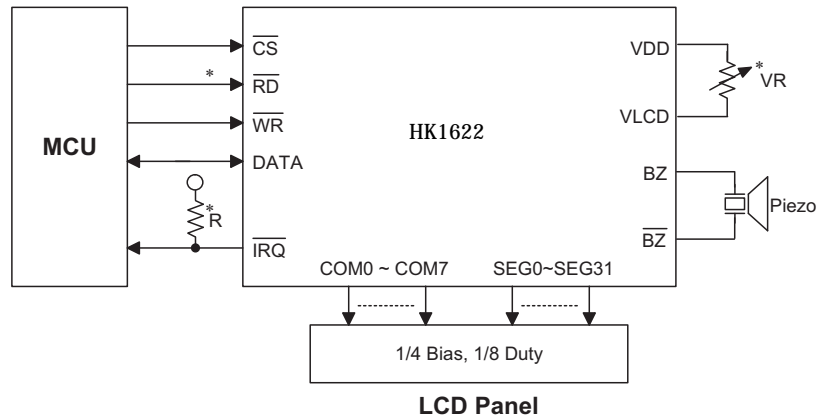

Note: The connection of $\overline{\text{IRQ}}$ and $\overline{\text{RD}}$ pin can be selected depending on the requirement of the MCU.
The voltage applied to V_{LCD} pin must be equal to or lower than V_{DD} .
Adjust VR to fit LCD display, at $V_{\text{DD}}=5\text{V}$, $V_{\text{LCD}}=4\text{V}$, $\text{VR}=15\text{k}\Omega\pm 20\%$.
Adjust R (external pull-high resistance) to fit user's time base clock.

Command Summary

Name	ID	Command Code	D/C	Function	Def.
READ	1 1 0	A5A4A3A2A1A0D0D1D2D3	D	Read data from the RAM	
WRITE	1 0 1	A5A4A3A2A1A0D0D1D2D3	D	Write data to the RAM	
READ-MODIFY-WRITE	1 0 1	A5A4A3A2A1A0D0D1D2D3	D	Read and Write data to the RAM	
SYS DIS	1 0 0	0000-0000-X	C	Turn off both system oscillator and LCD bias generator	Yes
SYS EN	1 0 0	0000-0001-X	C	Turn on system oscillator	
LCD OFF	1 0 0	0000-0010-X	C	Turn off LCD display	Yes
LCD ON	1 0 0	0000-0011-X	C	Turn on LCD display	
TIMER DIS	1 0 0	0000-0100-X	C	Disable time base output	Yes
WDT DIS	1 0 0	0000-0101-X	C	Disable WDT time-out flag output	Yes
TIMER EN	1 0 0	0000-0110-X	C	Enable time base output	
WDT EN	1 0 0	0000-0111-X	C	Enable WDT time-out flag output	
TONE OFF	1 0 0	0000-1000-X	C	Turn off tone outputs	Yes
CLR TIMER	1 0 0	0000-1101-X	C	Clear the contents of the time base generator	
CLR WDT	1 0 0	0000-1111-X	C	Clear the contents of WDT stage	
RC 32K	1 0 0	0001-10XX-X	C	System clock source, on-chip RC oscillator	Yes
EXT 32K	1 0 0	0001-11XX-X	C	System clock source, external clock source	
TONE 4K	1 0 0	010X-XXXX-X	C	Tone frequency output: 4kHz	
TONE 2K	1 0 0	0110-XXXX-X	C	Tone frequency output: 2kHz	
$\overline{\text{IRQ}}$ DIS	1 0 0	100X-0XXX-X	C	Disable $\overline{\text{IRQ}}$ output	Yes
$\overline{\text{IRQ}}$ EN	1 0 0	100X-1XXX-X	C	Enable $\overline{\text{IRQ}}$ output	

Name	ID	Command Code	D/C	Function	Def.
F1	1 0 0	101X-0000-X	C	Time base clock output: 1Hz The WDT time-out flag after: 4s	
F2	1 0 0	101X-0001-X	C	Time base clock output: 2Hz The WDT time-out flag after: 2s	
F4	1 0 0	101X-0010-X	C	Time base clock output: 4Hz The WDT time-out flag after: 1s	
F8	1 0 0	101X-0011-X	C	Time base clock output: 8Hz The WDT time-out flag after: 1/2s	
F16	1 0 0	101X-0100-X	C	Time base clock output: 16Hz The WDT time-out flag after: 1/4s	
F32	1 0 0	101X-0101-X	C	Time base clock output: 32Hz The WDT time-out flag after: 1/8s	
F64	1 0 0	101X-0110-X	C	Time base clock output: 64Hz The WDT time-out flag after: 1/16s	
F128	1 0 0	101X-0111-X	C	Time base clock output: 128Hz The WDT time-out flag after: 1/32s	Yes
TEST	1 0 0	1110-0000-X	C	Test mode, user don't use.	
NORMAL	1 0 0	1110-0011-X	C	Normal mode	Yes

Note: X : Don't care

A5~A0 : RAM address

D3~D0 : RAM data

D/C : Data/Command mode

Def. : Power on reset default

All the bold forms, namely **1 1 0**, **1 0 1**, and **1 0 0**, are mode commands. Of these, **1 0 0** indicates the command mode ID. If successive commands have been issued, the command mode ID except for the first command will be omitted. The source of the tone frequency and of the time base or WDT clock frequency can be derived from an on-chip 32kHz RC oscillator or an external 32768Hz clock. Calculation of the frequency is based on the system frequency sources as stated above. It is recommended that the host controllers should initialize the HK1622 after power on reset, for power on reset may fail, which in turn leads to the malfunctioning of the HK1622.

Package Information

44-pin QFP (10mm×10mm) Outline Dimensions

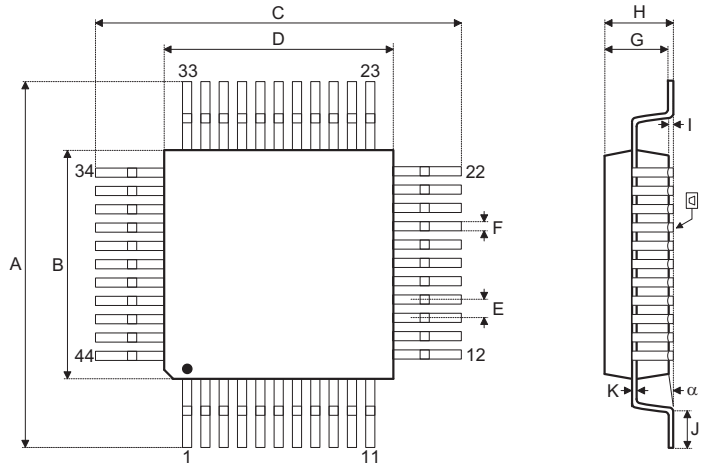

Symbol	Dimensions in inch		
	Min.	Nom.	Max.
A	0.512	—	0.528
B	0.390	—	0.398
C	0.512	—	0.528
D	0.390	—	0.398
E	—	0.031	—
F	—	0.012	—
G	0.075	—	0.087
H	—	—	0.106
I	0.010	—	0.020
J	0.029	—	0.037
K	0.004	—	0.008
L	—	0.004	—
α	0°	—	7°

Symbol	Dimensions in mm		
	Min.	Nom.	Max.
A	13.00	—	13.40
B	9.90	—	10.10
C	13.00	—	13.40
D	9.90	—	10.10
E	—	0.80	—
F	—	0.30	—
G	1.90	—	2.20
H	—	—	2.70
I	0.25	—	0.50
J	0.73	—	0.93
K	0.10	—	0.20
L	—	0.10	—
α	0°	—	7°

44-pin LQFP (10mm×10mm) (FP3.2mm) Outline Dimensions

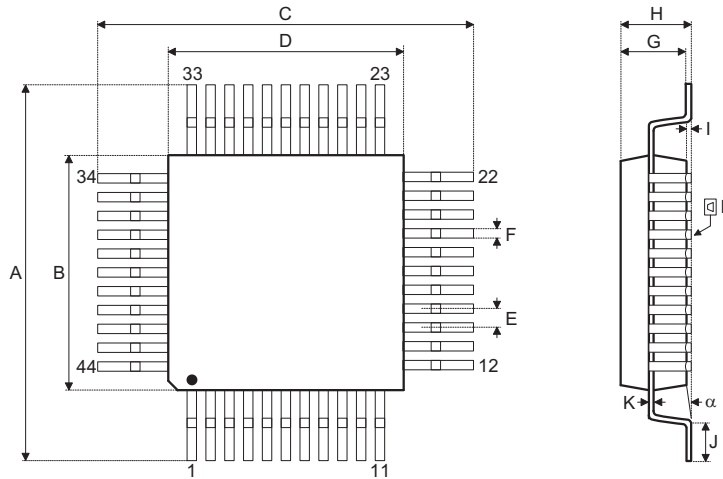

Symbol	Dimensions in inch		
	Min.	Nom.	Max.
A	0.512	0.520	0.528
B	0.390	0.394	0.398
C	0.512	0.520	0.528
D	0.390	0.394	0.398
E	—	0.031	—
F	—	0.012	—
G	0.053	0.055	0.057
H	—	—	0.063
I	0.004	—	0.010
J	0.041	0.047	0.053
K	0.004	—	0.008
α	0°	—	7°

Symbol	Dimensions in mm		
	Min.	Nom.	Max.
A	13.00	13.20	13.40
B	9.90	10.00	10.10
C	13.00	13.20	13.40
D	9.90	10.00	10.10
E	—	0.80	—
F	—	0.30	—
G	1.35	1.40	1.45
H	—	—	1.60
I	0.10	—	0.25
J	1.05	1.20	1.35
K	0.10	—	0.25
α	0°	—	7°

52-pin QFP (14mm×14mm) Outline Dimensions

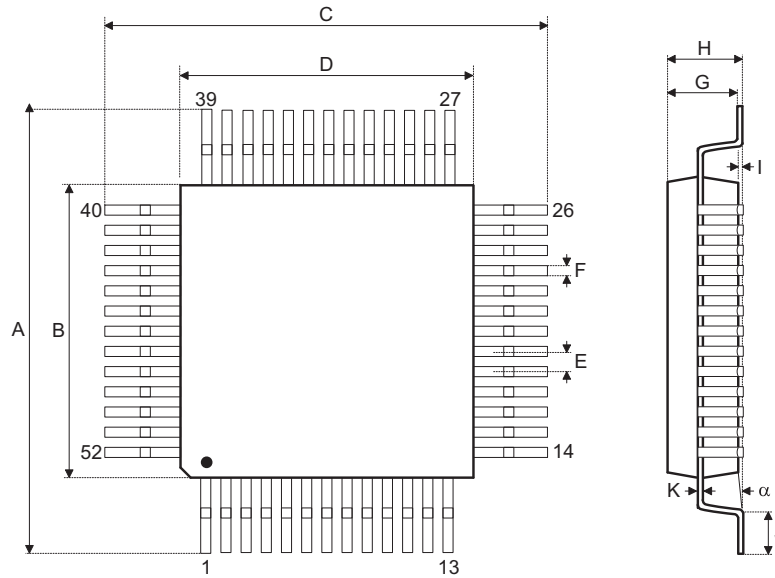

Symbol	Dimensions in inch		
	Min.	Nom.	Max.
A	0.681	—	0.689
B	0.547	—	0.555
C	0.681	—	0.689
D	0.547	—	0.555
E	—	0.039	—
F	—	0.016	—
G	0.098	—	0.122
H	—	—	0.134
I	—	0.004	—
J	0.029	—	0.041
K	0.004	—	0.008
α	0°	—	7°

Symbol	Dimensions in mm		
	Min.	Nom.	Max.
A	17.30	—	17.50
B	13.90	—	14.10
C	17.30	—	17.50
D	13.90	—	14.10
E	—	1.00	—
F	—	0.40	—
G	2.50	—	3.10
H	—	—	3.40
I	—	0.10	—
J	0.73	—	1.03
K	0.10	—	0.20
α	0°	—	7°

64-pin LQFP (7mm×7mm) Outline Dimensions

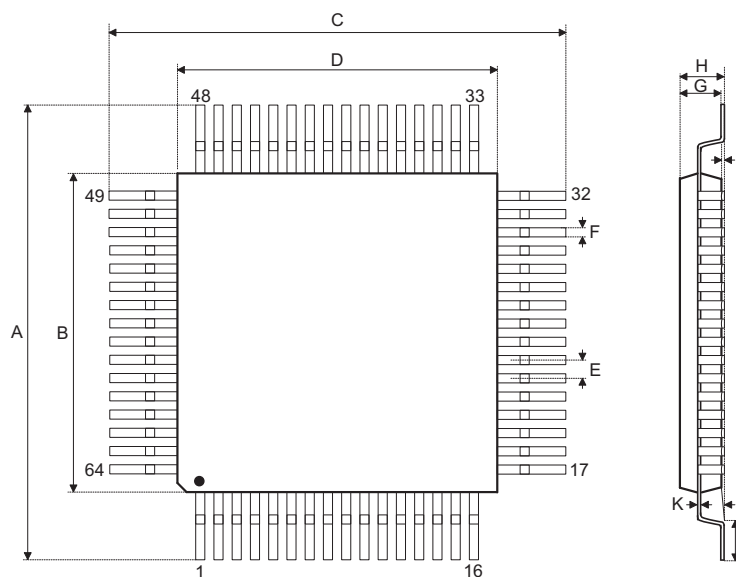

Symbol	Dimensions in inch		
	Min.	Nom.	Max.
A	0.350	—	0.358
B	0.272	—	0.280
C	0.350	—	0.358
D	0.272	—	0.280
E	—	0.016	—
F	0.005	—	0.009
G	0.053	—	0.057
H	—	—	0.063
I	0.002	—	0.006
J	0.018	—	0.030
K	0.004	—	0.008
α	0°	—	7°

Symbol	Dimensions in mm		
	Min.	Nom.	Max.
A	8.90	—	9.10
B	6.90	—	7.10
C	8.90	—	9.10
D	6.90	—	7.10
E	—	0.40	—
F	0.13	—	0.23
G	1.35	—	1.45
H	—	—	1.60
I	0.05	—	0.15
J	0.45	—	0.75
K	0.09	—	0.20
α	0°	—	7°